

ARAPAHOE TELEPHONE COMPANY

Exchange and Network
Services Catalog

State of Nebraska
Notified: 12-19-96

TITLE PAGE
Release 1
Effective: 1-2-97

TERMS, CONDITIONS, RATES AND CHARGES

Applying to the provision of intrastate

EXCHANGE AND NETWORK SERVICES

within the operating territory of

Arapahoe Telephone Company

dba ATC Communications

in the State of

NEBRASKA

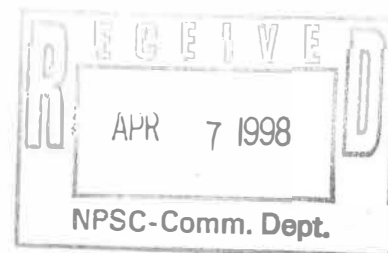

NOTICE
THE INFORMATION CONTAINED IN THIS DOCUMENT IS SUBJECT TO CHANGE.

ARAPAHOE TELEPHONE COMPANY

Exchange and Network
Services Catalog

SECTION 1

Index Page 1

Release 2

State of Nebraska

Notified: 5-1-14

Effective: 7-2-14

1. APPLICATION AND REFERENCE

SUBJECT	PAGE
Application of Catalog.....	1
Catalog Format.....	9
Explanation of Abbreviations.....	10
Explanation of Change Symbols.....	10
Subject Index.....	6
Table of Contents.....	2

NOTICE

THE INFORMATION CONTAINED IN THIS DOCUMENT IS SUBJECT TO CHANGE.

ARAPAHOE TELEPHONE COMPANY

Exchange and Network
Services Catalog

SECTION 1

Page 1

Release 2

Effective: 7-2-14

State of Nebraska
Notified: 5-1-14

1. APPLICATION AND REFERENCE

1.1 APPLICATION OF CATALOG

This Catalog contains the regulations, terms, conditions, rates and charges applicable to intrastate exchange and network services and equipment furnished by Arapahoe Telephone Company hereinafter referred to as the Company.

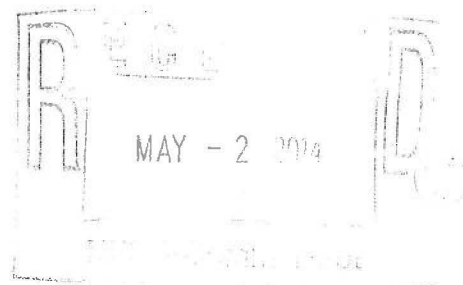

NOTICE
THE INFORMATION CONTAINED IN THIS DOCUMENT IS SUBJECT TO CHANGE.

ARAPAHOE TELEPHONE COMPANY

Exchange and Network
Services Catalog

SECTION 1

Page 2

Release 2

State of Nebraska

Notified: 5-1-14

Effective: 7-2-14

1. APPLICATION AND REFERENCE

1.2 TABLE OF CONTENTS

SECTION 1. APPLICATION AND REFERENCE

1.1	APPLICATION OF CATALOG.....	1
1.2	TABLE OF CONTENTS.....	2
1.3	SUBJECT INDEX.....	6
1.4	CATALOG FORMAT.....	9
1.4.1	LOCATION OF MATERIAL.....	9
1.4.2	OUTLINE STRUCTURE.....	9
1.4.3	RATE TABLES.....	9
1.4.4	USOC COLUMN.....	10
1.5	EXPLANATION OF CHANGE SYMBOLS.....	10
1.6	EXPLANATION OF ABBREVIATIONS.....	10

SECTION 2. GENERAL REGULATIONS - CONDITIONS OF OFFERING

2.1	DEFINITION OF TERMS.....	1
2.2	ESTABLISHING AND FURNISHING SERVICE.....	4
2.2.1	PROVISION OF SERVICE.....	4
2.2.2	OBLIGATION TO FURNISH SERVICE.....	7
2.2.3	LIMITED COMMUNICATION.....	7
2.2.4	ASSIGNING AND CHANGING OF TELEPHONE NUMBERS.....	8
2.2.5	TERMINATION OF SERVICE-COMPANY INITIATED.....	9
2.2.6	TEMPORARY SUSPENSION OF SERVICE-CUSTOMER INITIATED.....	11
2.2.7	SPECIAL ARRANGEMENTS.....	13
2.2.8	TERMINATION OF SERVICE.....	13
2.3	PAYMENT FOR SERVICE.....	15
2.3.1	CUSTOMER RESPONSIBILITY.....	15
2.3.2	PAYMENT OF BILLS.....	16
2.3.3	ADVANCE PAYMENTS.....	16
2.3.4	DEPOSITS.....	17
2.4	LIMITATIONS OF LIABILITY.....	17
2.4.1	LIMITATIONS.....	17
2.5	RESPONSIBILITIES OF PARTIES.....	19
2.5.1	COMPANY RESPONSIBILITY.....	19
2.5.2	CUSTOMER RESPONSIBILITY.....	20
2.5.3	COMMUNICATIONS SYSTEMS AND PREMISES WIRE.....	20
2.6	SPECIAL TAXES, FEES, AND CHARGES.....	21

NOTICE

THE INFORMATION CONTAINED IN THIS DOCUMENT IS SUBJECT TO CHANGE.

ARAPAHOE TELEPHONE COMPANY

Exchange and Network
Services Catalog

SECTION 1

Page 3

Release 2

State of Nebraska

Notified: 06-15-2012

Effective: 07-01-2012

1. APPLICATION AND REFERENCE

SECTION 3. SERVICE CHARGES

3.1	MISCELLANEOUS NONRECURRING CHARGES.....	1
3.1.1	NONRECURRING CHARGES.....	1
3.1.2	PREMISES WORK CHARGES.....	6
3.1.3	DUAL SERVICE.....	6

SECTION 4. CONSTRUCTION CHARGES AND OTHER SPECIAL CHARGES

4.1	GENERAL.....	1
4.2	UNUSUAL INSTALLATIONS.....	2
4.2.1	EXTENSIONS FOR NEW REAL ESTATE ADDITIONS.....	2

SECTION 5. EXCHANGE SERVICES

5.1	EXCHANGE AREAS.....	1
5.1.1	LIST OF EXCHANGE AREAS AND LOCAL CALLING AREAS.....	1
5.1.2	LOCAL SERVICE INCREMENTS.....	1
5.1.3	MAPS.....	2
5.2	LOCAL EXCHANGE SERVICE.....	2
5.2.1	MEASURED SERVICE.....	2
5.2.2	FLAT RATE SERVICE.....	9
5.2.3	TELEPHONE ASSISTANCE PROGRAMS.....	11
5.3	PREMIUM EXCHANGE SERVICE.....	14
5.3.1	CUSTOM CALLING SERVICES.....	14
5.4	PUBLIC COMMUNICATION SERVICE – COIN AND COINLESS.....	16
5.4.1	PUBLIC TELEPHONE SERVICE.....	16
5.4.2	SEMPUBLIC SERVICE.....	17
5.4.3	COINLESS PUBLIC TELEPHONE SERVICE.....	21
5.4.4	PUBLIC ACCESS LINE (PAL) SERVICE.....	21
5.5	DIRECTORY SERVICES.....	26
5.5.1	DIRECTORY LISTINGS.....	26
5.5.2	CUSTOM NUMBER SERVICE.....	33
5.6	OPERATOR SERVICES.....	35
5.6.1	INTERCEPT SERVICES.....	35
5.6.2	DIRECTORY ASSISTANCE SERVICE.....	37
5.6.3	SPECIAL REVERSED CHARGE SERVICE.....	38
5.6.4	OPERATOR VERIFICATION SERVICE.....	40

RECEIVED
MAY - 2 2014

NOTICE

THE INFORMATION CONTAINED IN THIS DOCUMENT IS SUBJECT TO CHANGE.

ARAPAHOE TELEPHONE COMPANY

Exchange and Network
Services Catalog

SECTION 1

Page 4

Release 2

State of Nebraska

Notified: 5-1-14

Effective: 7-2-14

1. APPLICATION AND REFERENCE

SECTION 6 RESERVED

SECTION 7 RESERVED

SECTION 8.

DIGITAL SUBSCRIBER LINE ACCESS SERVICES

8.1	ASYMMETRIC DIGITAL SUBSCRIBER LINE ACCESS SERVICE.....	1
8.1.1	GENERAL.....	1
8.1.2	LIMITATIONS.....	1
8.1.3	UNDERTAKING OF THE TELEPHONE COMPANY.....	1
8.1.4	OBLIGATIONS OF THE CUSTOMER.....	1
8.1.5	RATE REGULATIONS	1
8.2	SYMMETRIC DIGITAL SUBSCRIBER LINE ACCESS SERVICE.....	1
8.2.1	GENERAL.....	1
8.2.2	LIMITATIONS.....	1
8.2.3	UNDERTAKING OF THE TELEPHONE COMPANY.....	1
8.2.4	OBLIGATIONS OF THE CUSTOMER.....	1
8.2.5	RATE REGULATIONS	1
8.3	RESERVED FOR FUTURE USE.....	1
8.4	RESERVED FOR FUTURE USE.....	1
8.5	DIGITAL SUBSCRIBER LINE ACCESS SERVICES WHOLESALE PRICING PLAN.....	1
8.5.1	GENERAL.....	1
8.5.2	TERM PLAN.....	1

SECTION 9.

CENTRAL OFFICE SERVICE

9.1	EMERGENCY REPORTING SERVICE.....	1
9.1.1	UNIVERSAL EMERGENCY NUMBER SERVICE - 911.....	1

SECTION 10.

MISCELLANEOUS SERVICE OFFERINGS

10.1	MILEAGE CHARGES.....	1
10.2	SCREENING/RESTRICTION SERVICES.....	1
10.2.1	TOLL SCREENING SERVICE.....	1
10.2.2	BILLED NUMBER SCREENING (BNS).....	3
10.2.3	TOLL RESTRICTION.....	3
10.2.4	PAY PER CALL RESTRICTION.....	4
10.2.5	BLOCKING FOR 10XXX1+/10XXX011+.....	4

NOTICE

THE INFORMATION CONTAINED IN THIS DOCUMENT IS SUBJECT TO CHANGE.

ARAPAHOE TELEPHONE COMPANY

Exchange and Network
Services Catalog

SECTION 1

Page # 5

Release 2

State of Nebraska

Notified: 5-1-14

Effective: 7-2-14

1. APPLICATION AND REFERENCE

10.3	CALLER IDENTIFICATION BLOCKING OPTIONS.....	5
10.3.1	CALLER IDENTIFICATION BLOCKING-PER CALL.....	5
10.3.2	CALLER IDENTIFICATION BLOCKING-ALL CALL.....	5
10.4	CONNECTION OF PREMISES EQUIPMENT TO TELECOMMUNICATIONS SERVICES.....	6
10.4.1	DATA AND TELETYPEWRITER EQUIPMENT.....	6
10.4.2	RECORDING, REPRODUCING AND AUTOMATIC ANSWERING AND RECORDING EQUIPMENT.....	7
10.4.3	ALARM REPORTING EQUIPMENT.....	9
10.4.4	MULTI-LINE TERMINATING SYSTEMS AND COMMUNICATIONS SYSTEMS.....	10
10.4.5	POWER FAILURE OPTIONS.....	11
10.4.6	TELEPHOTOGRAPH EQUIPMENT.....	11

SECTION 11. OBSOLETE EXCHANGE SERVICES

11.1	REMOTE LOCATION LINE SERVICE.....	1
------	-----------------------------------	---

SECTION 12 RESERVED

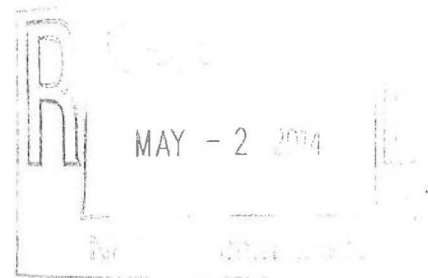

ARAPAHOE TELEPHONE COMPANY

**Exchange and Network
Services Catalog**

SECTION 1

Page 5

Release 2

State of Nebraska

Notified: 5-1-14

Effective: 7-2-14

1. APPLICATION AND REFERENCE

SECTION 13.

CUSTOMER PREMISES WIRE AND MAINTENANCE PLANS

13.1 CUSTOMER PREMISES WIRE..... 1
13.2 PREMISES WIRE MAINTENANCE..... 15

SECTION 14 RESERVED

SECTION 15 RESERVED

SECTION 16.

PROMOTIONS

16.1 SPECIAL PROMOTIONS..... 1

NOTICE

THE INFORMATION CONTAINED IN THIS DOCUMENT IS SUBJECT TO CHANGE.

ARAPAHOE TELEPHONE COMPANY

Exchange and Network
Services Catalog

SECTION 1

Page 6

Release 2

State of Nebraska
Notified: 06-15-2012

Effective: 07-01-2012

1. APPLICATION AND REFERENCE

1.3 SUBJECT INDEX

SECTION

Access Recovery Charge.....	2
Advance Payments.....	2
Alarm Reporting Equipment.....	10
Annoyance Calls.....	2
Application of Catalog.....	1
Application of Rates by Use of Service.....	2
Assigning and Changing of Telephone Numbers.....	2
Billed Number Screening (BNS).....	10
Blocking For 10XXX1+/10XXX011+.....	10
Broadcast of Recorded Telephone Conversations.....	2
Building Space and Electric Power Supply.....	2
Caller Identification Blocking--All Call.....	10
Caller Identification Blocking--Per Call.....	10
Caller Identification Blocking Options.....	10
Cancellations.....	2
Catalog Format.....	1
Change of Responsibility.....	2
Coinless Public Telephone Service.....	5
Communication Impaired Surcharge.....	2
Communications Systems and Premises Wire.....	2
Company Responsibility.....	2
Connections of Equipment, Communications Systems and Premises Wire.....	2
Connections of Premises Equipment to Telecommunications Services.....	10
Custom Calling Services.....	5
Customer Number Service.....	5
Customer Premises Wire.....	13
Customer Responsibility.....	2
Data and Teletypewriter Equipment.....	10
Defacement of Premises.....	2
Deferment of Start of Service.....	2
Definition of Terms.....	2
Deposits.....	2
Directory Assistance.....	5
Directory Listings.....	5
Dual Service.....	3
EAS Group.....	5
Emergency Reporting Service.....	9
Establishing and Furnishing Service.....	2
Exchange Areas.....	5
Explanation of Abbreviations.....	1
Explanation of Change Symbols.....	1
Extended Area Service.....	5
Extensions for New Real Estate Additions.....	4
Flat Rate Service.....	2

MAY 5 - 2 2014

NOTICE

THE INFORMATION CONTAINED IN THIS DOCUMENT IS SUBJECT TO CHANGE.

ARAPAHOE TELEPHONE COMPANY

Exchange and Network Services Catalog

SECTION 1

Page 7

Release 1

Effective: 1-2-97

State of Nebraska

Notified: 12-19-96

1. APPLICATION AND REFERENCE

Fraud.....	2
Full Toll Denial.....	2
Hunting Service.....	5
Initial Service Periods.....	2
Intercept Services.....	5
Interest on Deposits.....	2
Late Payment Charge.....	2
Lifeline.....	5
Limitations.....	2
Limitations of Liability.....	2
Limited Communication.....	2
Link Up Nebraska.....	5
Local Calling Areas.....	5
Lost and Damaged Equipment.....	2
Maintenance and Repair.....	2
Measured Service.....	5
Mileage Charges.....	10
Miscellaneous Nonrecurring Charges.....	3
Multi-Line Terminating Systems and Communications Systems.....	10
Nonrecurring Charges.....	3
Obligation to Furnish Service.....	2
Operator Verification Service.....	5
Outgoing and Incoming Service Privileges.....	2
Payment for Service.....	2
Payment of Bills.....	2
Pay Per Call Restriction.....	10
Performance of Work on Customers' Premises.....	2
Power Failure Options.....	10
Premises Wire Maintenance.....	13
Premises Work Charges.....	3
Protection of Equipment and Facilities.....	2
Provision of Service.....	2
Public Access Line (PAL) Service.....	5
Public Telephone Service.....	5
Recording, Reproducing and Automatic Answering and Recording Equipment.....	10
Remote Location Line Service.....	11
Responsibilities of Parties.....	2
Restoration of Service.....	2
Returned Check Charge.....	2
Scope of General Terms and Conditions.....	2

NOTICE

THE INFORMATION CONTAINED IN THIS DOCUMENT IS SUBJECT TO CHANGE.

ARAPAHOE TELEPHONE COMPANY

Exchange and Network
Services Catalog

SECTION 1

Page 8

Release 1

State of Nebraska
Notified: 12-19-96

Effective: 1-2-97

1. APPLICATION AND REFERENCE

Semipublic and Shared Payphone Service.....	5
Service Connection Charge.....	3
Special Arrangements.....	2
Special Promotions.....	16
Special Reversed Charge Service.....	5
Special Taxes, Fees and Charges.....	2
Subject Index.....	1
Table of Contents.....	1
Tampering with Equipment.....	2
Telephone Number Assignment.....	2
Telephotography Equipment.....	10
Temporary Suspension of Service—Customer Initiated.....	2
Termination Liability/Waiver Policy.....	2
Termination of Service.....	2
Termination of Service—Company Initiated.....	2
Termination of Refusal of Service.....	2
Toll Restriction.....	10
Toll Screening Service.....	10
Transmission of Messages.....	2
Universal Emergency number Service – 911.....	9
Unusual Installations.....	4
Use of Service.....	2
Use of Service for Unlawful Purposes.....	2
Zoned Service.....	5

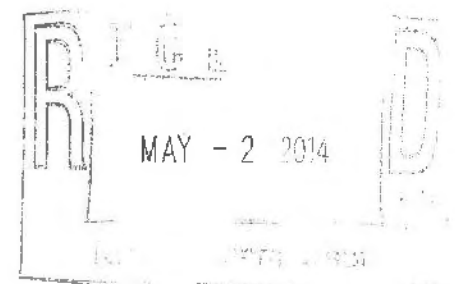

ARAPAHOE TELEPHONE COMPANY

Exchange and Network
Services Catalog

SECTION 1

Page 9

Release 1

State of Nebraska

Notified: 12-19-96

Effective: 1-2-97

1. APPLICATION AND REFERENCE

1.4 CATALOG FORMAT

1.4.1 LOCATION OF MATERIAL

- A. Section 1 provides the following for all of the sections in this Catalog.
- Subject Index – an alphabetical listing to find the desired section.
 - Table of Contents – a numerical listing to find the desired section and page.
- B. Each individual section in the Catalog provides a Subject Index for the material located within that section.

1.4.2 OUTLINE STRUCTURE

The Catalog uses nine levels of indentations known as Tariff Information Management (TIM) Codes, as outlined below:

LEVEL	APPLICATION	EXAMPLE
1	Section Heading	1. APPLICATION AND REFERENCE
2	Sub Heading	1.4 CATALOG FORMAT
3	Sub Heading	1.4.1 LOCATION OF MATERIAL
4	Sub Heading/Tariff Text	A. Text
5	Sub Heading/Tariff Text	1. Text
6	Sub Heading/Tariff Text	a. Text
7	Sub Heading/Tariff Text	(1) Text
8	Sub Heading/Tariff Text	(a) Text
9	Sub Heading/Tariff Text	[1] Text

1.4.3 RATE TABLES

Within rate tables, four types of entries are allowed:

- Rate Amount
The rate amount indicates the dollar value associated with the service.
- A dash “–”
The dash indicates that there is no rate for the service or that a rate amount is not applicable under the specific column header.
- A footnote designator “[1]”
The footnote designator indicates that further information is contained in a footnote.

NOTICE

THE INFORMATION CONTAINED IN THIS DOCUMENT IS SUBJECT TO CHANGE.

ARAPAHOE TELEPHONE COMPANY

Exchange and Network
Services Catalog

SECTION 1

Page 10

Release 1

State of Nebraska
Notified: 12-19-96

Effective: 1-2-97

1. APPLICATION AND REFERENCE

- ICB

The acronym "ICB" indicates that the product/service is rated on an individual case basis.

1.4.4 USOC COLUMN

Within USOC columns, two types of entries are allowed:

- USOC

The three- or five-character code for the product or service.

- N/A

The "N/A" indicates that there is no applicable USOC.

1.5 EXPLANATION OF CHANGE SYMBOLS

SYMBOL	EXPLANATION
(C)	To signify changed term or condition.
(D)	To signify discontinued material.
(I)	To signify rate increase.
(M)	To signify material moved from or to another part of the Catalog with no change, unless there is another change symbol present.
(N)	To signify new material.
(R)	To signify rate reduction.
(T)	To signify a change in text but no change in rate, term or condition.

1.6 EXPLANATION OF ABBREVIATIONS

ACD	- Automatic Call Distributor
ACT	- Automatic Call Transfer
ADSL	- Asymmetric Digital Subscriber Line
AIOD	- Automatic Identified Outward Dialing
ALI	- Automatic Location Identification
ANI	- Automatic Number Identification
AR	- Alternate Routing
ARS	- Automatic Route Selection
BNS	- Bill Number Screening
CCSA	- Common Control Switching Arrangement
CDAR	- Customer Dialed Account Recording
CFBDA	- Call Forwarding Busy Don't Answer
CNCC	- Customer Network Control Center

RECEIVED
MAY - 2 2016

NOTICE

THE INFORMATION CONTAINED IN THIS DOCUMENT IS SUBJECT TO CHANGE.

ARAPAHOE TELEPHONE COMPANY

Exchange and Network
Services Catalog

SECTION 1

Page 11

Release 2

State of Nebraska
Notified: 5-1-14

Effective: 7-2-14

1. APPLICATION AND REFERENCE

CO	- Central Office
Cont'd	- Continued
CPE	- Customer Premises/Provided Equipment
dB	- Decibel
DC	- Direct Current
DID	- Direct-Inward-Dialing
DMS	- Data Management System
DR	- Default Routing
DSL	- Digital Subscriber Line
DSS	- Digital Switched Service
ENI	- Extended Network Interface
ESN	- Emergency Service Number
ESS	- Electronic Switching System
FCC	- Federal Communications Commission
FCO	- Foreign Central Office
FX	- Foreign Exchange
Hz	- Hertz
IC	- Interexchange Carrier
ICB	- Individual Case Basis
kbps	- Kilobits per Second
kHz	- kilohertz
LATA	- Local Access and Transport Area
mHz	- megahertz
MSAG	- Master Street Address Guide
MTS	- Message Telecommunications Service
MWI	- Message Waiting Indication
NAR	- Network Access Register
NAS	- Network Access Service
NPA	- Numbering Plan Area
OCC	- Other Common Carrier
PAL	- Public Access Line
PBX	- Private Branch Exchange
PDN	- Primary Directory Number
PSAP	- Public Safety Answering Point
RSP	- Rate Stability Plan
SDN	- Secondary Directory Number
SDSL	- Symmetric Digital Subscriber Line
SMDR	- Station Message Detail Recording
SR	- Selective Routing
SRA	- Selective Routing Arrangement
TDD	- Telecommunications Device for the Deaf
TDRS	- Traffic Data Report Service
TSP	- Telecommunications Service Priority
UCD	- Uniform Call Distributor
USOC	- Uniform Service Order Code
V & H	- Vertical and Horizontal
VMS	- Voice Messaging Service

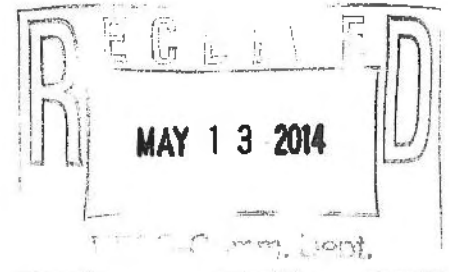

NOTICE

THE INFORMATION CONTAINED IN THIS DOCUMENT IS SUBJECT TO CHANGE.

ARAPAHOE TELEPHONE COMPANY

Exchange and Network
Services Catalog

SECTION 2

Index Page 1

Release 1

Effective: 1-2-97

State of Nebraska

Notified: 12-19-96

2. GENERAL TERMS AND CONDITIONS OF OFFERING

SUBJECT	PAGE
Advance Payments	16
Annoyance Calls	10
Application of Rates by Use of Service	4
Assigning and Changing of Telephone Numbers	8
Broadcast of Recorded Telephone Conversations	20
Building Space and Electric Power Supply	20
Cancellations	7
Change of Responsibility	6
Communication Impaired Surcharge	21
Communications Systems and Premises Wire	20
Company Responsibility	19
Connections of Equipment, Communications Systems and Premises Wire	20
Customer Responsibility	15
Customer Responsibility	20
Defacement of Premises	18
Deferment of Start of Service	7
Definition of Terms	1
Deposits	17
Establishing and Furnishing Service	4
Fraud	10
Full Toll Denial	10
Initial Service Periods	13
Interest on Deposits	17
Late Payment Charge	16
Limitations	17
Limitations of Liability	17
Limited Communication	7
Lost and Damaged Equipment	20
Maintenance and Repair	19
Obligation to Furnish Service	7
Outgoing and Incoming Service Privileges	18

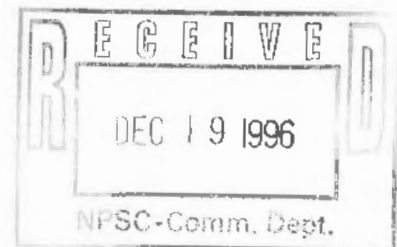

NOTICE

THE INFORMATION CONTAINED IN THIS DOCUMENT IS SUBJECT TO CHANGE.

ARAPAHOE TELEPHONE COMPANY

Exchange and Network
Services Catalog

SECTION 2

Index Page 2

Release 1

State of Nebraska

Notified: 12-19-96

Effective: 1-2-97

2. GENERAL TERMS AND CONDITIONS OF OFFERING

SUBJECT	PAGE
Payment for Service	15
Payment of Bills	16
Performance of Work on Customers' Premises	19
Protection of Equipment and Facilities	20
Provision of Service	4
Responsibilities of Parties.....	19
Restoration of Service	11
Returned Check Charge.....	16
Scope of General Terms and Conditions.....	1
Special Arrangements.....	13
Special Taxes, Fees and Charges	21
Tampering with Equipment	10
Telephone Number Assignment.....	8
Temporary Suspension of Service-Customer Initiated	11
Termination Liability/Waiver Policy.....	14
Termination of Service.....	13
Termination of Service-Company Initiated	9
Termination or Refusal of Service.....	9
Transmission of Messages	18
Transmission of Messages	20
Use of Service	4
Use of Service for Unlawful Purposes.....	10

The General Terms and Conditions of Offering govern the provision of telephone service and facilities by the Company and apply in addition to any terms and conditions contained in this Catalog.

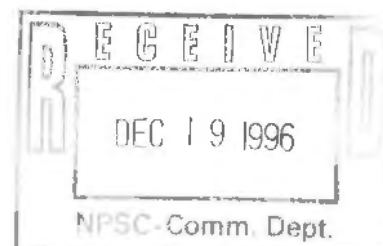

ARAPAHOE TELEPHONE COMPANY

Exchange and Network
Services Catalog

SECTION 2

Page 1

Release 1

State of Nebraska
Notified: 12-19-96

Effective: 1-2-97

2. GENERAL TERMS AND CONDITIONS OF OFFERING

2.1 DEFINITION OF TERMS

Accessories

Devices which are mechanically attached to, or used with, the facilities furnished by the Company and which are independent of, and not electrically, acoustically or inductively connected to, the communications path of the telecommunications system.

Additional Telephone Set Line

Consists of wiring on a customer's premises to the jack or outlet of the Additional Telephone Set service location, other than the inside wiring associated with the jack or outlet for access line service.

Additional Telephone Set Service

Provides the capability for originating calls from or receiving calls at instruments provided at locations in addition to the location of the access line service.

Building

A structure occupied by one or more customers.

Campus

A group of two or more buildings or spaces located on a single owned continuous or contiguous property.

Conforming Answering Device

A customer-provided device which automatically answers incoming calls; transmits a prerecorded voice message or appropriate audible signal to the calling party; records a voice message from the calling party if so designed and arranged; and automatically disconnects from the line in a prearranged manner on completion of the last of the functions for which it was designed and arranged as described in this paragraph. The Conforming Answering Device may include remote interrogation and/or device function control.

Continuous Portions of a Building

The term "Continuous Portions of a Building" denotes spaces within a given building which are occupied by the customer and connected by doors, hallways, stairs or elevators and not separated by space occupied by others or used by the general public.

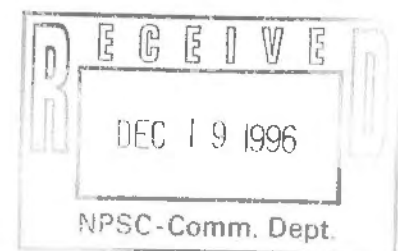

NOTICE

THE INFORMATION CONTAINED IN THIS DOCUMENT IS SUBJECT TO CHANGE.

ARAPAHOE TELEPHONE COMPANY

Exchange and Network
Services Catalog

SECTION 2

Page 2

Release 1

Effective: 1-2-97

State of Nebraska

Notified: 12-19-96

2. GENERAL TERMS AND CONDITIONS OF OFFERING

Continuous Property

Continuous Property is defined as the land, including any buildings or buildings thereon, occupied by a customer that may be served without crossing a public street, right-of-way or the property of another. Noncontinuous property is treated as continuous if the customer furnishes a passageway which is suitable to the Company for the placing of wire facilities. Pipe and conduits are considered enclosed passageways.

Customer

The person, firm or corporation responsible for the payment of charges and compliance with the conditions of the Company.

Customer-Provided Terminal Equipment

Devices or apparatus and their associated wiring, provided by a customer, which do not constitute a communications system and which, when connected to the communications path of the telecommunications system, are so connected either electrically, acoustically or inductively.

Data Access Arrangement

A protective connecting arrangement for use with the network control signaling unit, or in lieu of the connecting arrangement, an arrangement to identify a central office line and protective facilities and procedures to determine compliance with criteria set forth in Group Use Exchange Service.

Demarcation Point

The point of interconnection between the Company's regulated telecommunications facilities and terminal equipment, protective apparatus or wiring at a premises.

Direct Electrical Connection

A physical connection of the electrical conductors in the communications path.

Entrance Facilities

Entrance Facilities are those facilities from the property line to the point at which the cable enters the premises and terminates at the protector.

Facilities

Central office equipment, supplemental equipment, apparatus, wiring, cables (outside plant feeder and distribution) and other materials and mechanisms necessary to or furnished in connection with telephone service.

NOTICE

THE INFORMATION CONTAINED IN THIS DOCUMENT IS SUBJECT TO CHANGE.

RECEIVED
DEC 19 1996
NPSG-Comm. Dept.

ARAPAHOE TELEPHONE COMPANY

Exchange and Network
Services Catalog

SECTION 2

Page 3

Release 1

Effective: 1-2-97

State of Nebraska
Notified: 12-19-96

2. GENERAL TERMS AND CONDITIONS OF OFFERING

Inside Wire

Telephone wiring located on the building owner's/customer's side of the Demarcation point. Such wiring is deregulated. Installation and maintenance of Inside Wire is the responsibility of the customer or premises owner.

Interface

That point on the premises of the customer at which provision is made for connection of other than the Company provided facilities to facilities provided by the Company.

Network Control Signaling

The transmission of signals used in the telecommunications system which perform functions such as supervision (control, status and charging signals), address signaling (e.g., dialing), calling and called number identification, audible tone signals (call progress signals indicating reorder or busy conditions, alerting, coin denominations, coin collect and coin return tones) to control the operation of switching machines in the telecommunications system.

Network Facilities

All Company facilities from the central office up to and including the Standard Network Interface at the Demarcation point.

Premises

A tract of land. This tract of land may have one or more building structures or individual space or units on its grounds. There may be individual space or units also within this building structure.

Protector

An electrical device located in a central office, a customer's premises or anywhere along the telephone facility path. This device protects both the Company's and the customer's property and facilities from high voltages and surges in current.

Standard Network Interface (SNI)

The SNI is a standard FCC registration jack or its equivalent which is provided, installed, owned and maintained by the Company at the customer's premises. The SNI is placed at the point on the customer's premises where all premises services are connected to the telecommunication's network via Company or customer owned facilities/wire.

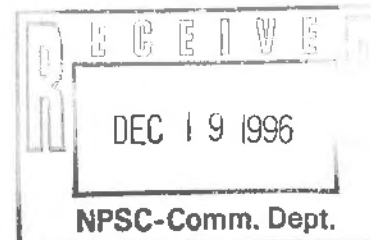

ARAPAHOE TELEPHONE COMPANY

Exchange and Network
Services Catalog

SECTION 2

Page 4

Release 1

State of Nebraska
Notified: 12-19-96

Effective: 1-2-97

2. GENERAL TERMS AND CONDITIONS OF OFFERING

Supporting Structure

Consisting of, but not limited to, pipes, poles, trenches, backboards, plenum spaces, etc.; as required for the physical placement, protection and support of telephone facilities. These structures are furnished, installed and maintained at the expense of the premises owner for use by the Company in terminating regulated facilities.

2.2 ESTABLISHING AND FURNISHING SERVICE

2.2.1 PROVISION OF SERVICE

A. Use of Service

1. Telephone service is furnished to customers for use only by customers, their family, guests, or persons residing with them as members of their household; persons leasing or subleasing their residence during their temporary absence from such premises, or by their employees or representatives when engaged in business; except as the use is extended to others under the established terms and conditions governing, semipublic message rate, semipublic telephone service, and except as the use of the service may be extended to joint users under the established terms and conditions governing joint user service. Additional telephone service may be installed at locations not on the customers' premises only when there is other telephone service at those locations adequate, in the opinion of the Company, to take care of exchange and toll requirements. Such service is installed subject to the transmission limitations of exchange circuits.
2. A customer shall not provide switched voice or data communications between local exchange areas, including the bridging of Extended Area Service (EAS) zones, using underlying services from this Catalog.
3. Application of Rates by Use of Service
 - a. Service is classified as business service and business rates apply when any of the following conditions exist:
 - (1) When the service is furnished at a location where a business, trade or practice is performed and where use of the location is not confined primarily to domestic activities.
 - Service for social clubs (e.g., Elks, VFW, Eagles, etc.) will be considered business service.
 - (2) When the directory listing is to be a business listing.
 - (3) When the service is provided to or through a reseller of local exchange service.

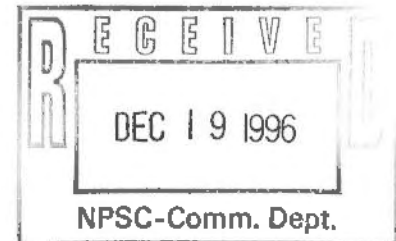

NOTICE

THE INFORMATION CONTAINED IN THIS DOCUMENT IS SUBJECT TO CHANGE.

ARAPAHOE TELEPHONE COMPANY

Exchange and Network
Services Catalog

SECTION 2

Page 5

Release 1

Effective: 1-2-97

State of Nebraska
Notified: 12-19-96

2. GENERAL TERMS AND CONDITIONS OF OFFERING

- b. Service is classified as residence service and residence rates apply when the following two conditions exist:
- (1) When the service is furnished at a location used primarily for domestic purposes; a residence location typically contains cooking and sleeping facilities.
 - Residence service will be allowed for individual rooms at group homes, e.g., patient rooms at retirement homes, boarding houses, when service to the rooms is not provided through a reseller of local exchange service, if the listing is in an individual's name.
 - Residence service will be allowed in church living quarters and the clergy person's private study if the listing is in an individual's name.
 - (2) When the directory listing is to be a residential listing. A residence service may not have a business directory listing.
- c. A residence service may not be part of a hunting sequence that contains business lines.
- d. Customers changing from business to residence service will be assigned a different telephone number. Referral of calls to the new residence telephone number assigned will not be provided.
- e. Customers may choose to retain the same telephone number but must continue to pay business rates until the next telephone directory is issued by the Company's directory publishing company, in which their telephone number does not appear as a business listing.
- f. When it is determined that a customer with residence service should be reclassified as business service under the above provisions, the Company will discontinue the service in the event such customer refuses to permit the service to be classified as business service and pay applicable business rates.
- g. The prices for services, including any and all discounts to which the customer may be entitled will be offered and charged to customers independently from and regardless of the customer's purchase of any customer premises equipment or enhanced services from the Company.

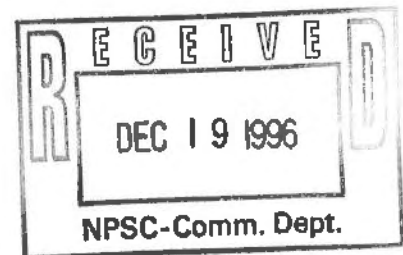

ARAPAHOE TELEPHONE COMPANY

Exchange and Network
Services Catalog

SECTION 2

Page 6

Release 1

State of Nebraska
Notified: 12-19-96

Effective: 1-2-97

2. GENERAL TERMS AND CONDITIONS OF OFFERING

B. Change of Responsibility

1. When a person, firm, partnership, corporation, club, or association attempts to become a telephone customer either through taking over an existing service and the associated telephone number or numbers, or to obtain service by means of a specific previously used telephone number or numbers, or to have calls transformed from such previously used telephone number to an established service, all ongoing rates, charges, and contract obligations, shall be made known, in writing to the requesting customer. Assignment of the number or numbers, or transfer of call to the requesting customer, will be at the discretion of the Company and conditioned upon receipt of the requesting customer's written acceptance of responsibility of all such ongoing rates, charges, and contract obligations, except where such requirement is forbidden by law as in some cases of bankruptcy.
2. The customer is responsible for notifying the Company in advance of date the service is to be transferred. The previous customer will receive a closing final bill as of the date of the transfer. There must be no break in service.
3. If a new customer does not choose to use the old number, transfer of calls from the old to the new number will not be provided.
4. Change of responsibility applies for ongoing rates, charges and contractual obligations when a new customer takes over the account except as specified in 3.1.1.C.9., or when a customer regrades from residence to business service and requests a final bill.

	USOC	NONRECURRING CHARGE
• Charge for change of responsibility		
- Residence	SBG	\$ 10.00
- Business	SBG	10.00

C. Deferments and Cancellations

When a Customer cancels or defers an order for service before the service is activated, a charge applies to allow the Company to recover the nonrecoverable costs of engineering, labor, material and equipment in case of cancellation, or sustain an investment beyond a reasonable period in case of deferral. Charges apply as follows:

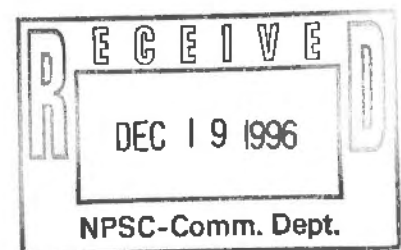

NOTICE

THE INFORMATION CONTAINED IN THIS DOCUMENT IS SUBJECT TO CHANGE.

ARAPAHOE TELEPHONE COMPANY

Exchange and Network
Services Catalog

SECTION 2

Page 7

Release 1

Effective: 1-2-97

State of Nebraska
Notified: 12-19-96

2. GENERAL TERMS AND CONDITIONS OF OFFERING

1. Cancellations

The charge is equal to the nonrecoverable costs incurred prior to the request for cancellation and the costs of removal, restoration and disposal, if any, to comply with cancellation. These costs include engineering, labor and nonrecoverable material and equipment expense, among others. The maximum amount charged shall not exceed the total of all nonrecurring minimum monthly and termination charges which would have applied had the service as ordered been established.

2. Deferment of Start of Service

- a. If the request for deferment is received by the Company prior to the date an order for the material is placed with its supplier - no charge shall apply.
- b. If the request for deferment is received by the Company subsequent to the date the order for the material was placed with its supplier:
 - For deferments of up to 90 days beyond the original agreed upon start service date - no charge shall apply.
 - For deferments extending beyond 90 days, a monthly recurring charge based upon costs incurred prior to the request for deferment applies. The monthly charge equals the deferred investment times the monthly prime interest rate plus recurring costs resulting directly from deferral, such as storage, taxes, etc. In addition, any extraordinary nonrecurring costs resulting from the deferral, such as additional engineering and labor, or transportation, shall be billed in total. Billing shall start the beginning of the fourth month of deferment and extend to the start of service. Charges shall not exceed the monthly rate which would have applied had the service been established.

2.2.2 OBLIGATION TO FURNISH SERVICE

The Company's obligation to furnish service or to continue to furnish service is dependent on its ability to obtain, retain and maintain suitable rights and facilities, and to provide for the installation of those facilities required incident to the furnishing and maintenance of that service.

2.2.3 LIMITED COMMUNICATION

The Company reserves the right to limit the length of conversation when necessary in times of emergency resulting in a shortage of facilities.

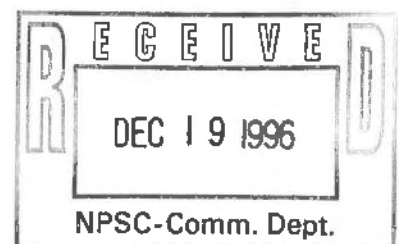

NOTICE

THE INFORMATION CONTAINED IN THIS DOCUMENT IS SUBJECT TO CHANGE.

ARAPAHOE TELEPHONE COMPANY

Exchange and Network
Services Catalog

SECTION 2

Page 8

Release 1

Effective: 1-2-97

State of Nebraska
Notified: 12-19-96

2. GENERAL TERMS AND CONDITIONS OF OFFERING

2.2.4 ASSIGNING AND CHANGING OF TELEPHONE NUMBERS

A. Telephone Number Assignment

The Company does not undertake to continue the furnishing of service to a customer in any exchange area through any particular central office in that area and may exchange the telephone number of the central office designation whenever it deems it desirable in the conduct of its business.

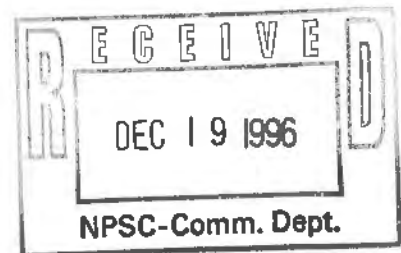

NOTICE
THE INFORMATION CONTAINED IN THIS DOCUMENT IS SUBJECT TO CHANGE.

ARAPAHOE TELEPHONE COMPANY

Exchange and Network
Services Catalog

SECTION 2

Page 9

Release 1

Effective: 1-2-97

State of Nebraska
Notified: 12-19-96

2. GENERAL TERMS AND CONDITIONS OF OFFERING

2.2.5 TERMINATION OF SERVICE-COMPANY INITIATED

A. Termination or Refusal of Service

1. The Company may either temporarily deny service or terminate the service upon:

- Nonpayment of Local or Long Distance nonrecurring charges.
- Use of foul or profane language.
- Impersonation of another with fraudulent intent.
- The abuse of fraudulent use of service or facilities to transmit a message or to locate a person or otherwise to give or obtain information without payment of a message toll charge.
- Abandonment of the service.
- Use of service in such a way as to interfere with the service of other customers.
- Use of service for unlawful purposes.
- Any other violation of the Company's terms and conditions.

2. The Company may disconnect, without advance notice:

- a. Any telephone service which is used in such a manner as to interfere with the service of other telephone users.
- b. Any facilities used for a call or calls, anonymous or otherwise, if in a manner reasonably to be expected to frighten, abuse, torment, or harass another.
- c. Any telephone service used by a customer in connection with a plan or contrivance to secure a large volume of telephone calls to be directed to such customer or the telephone of any designated customer at or about the same time, resulting in preventing, obstructing or delaying the telephone service of others.
- d. Any telephone service that is used for any purpose other than as a means of communication.
- e. Following the disconnection of service for any of these reasons, the Company will immediately notify the telephone customer thereof.

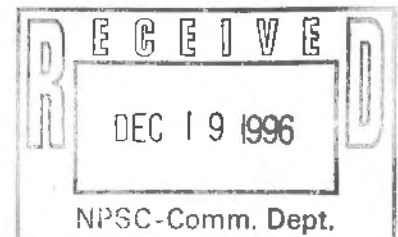

NOTICE

THE INFORMATION CONTAINED IN THIS DOCUMENT IS SUBJECT TO CHANGE.

ARAPAHOE TELEPHONE COMPANY

Exchange and Network
Services Catalog

SECTION 2

Page 10

Release 1

State of Nebraska

Notified: 12-19-96

Effective: 1-2-97

2. GENERAL TERMS AND CONDITIONS OF OFFERING

3. When the general telephone service to the public is impaired by a customer's use of exchange telephone service, the Company shall have the right to require the customer to contract for and properly operate as many additional telephone lines as are needed to adequately serve the customer's requirements, or to discontinue the service of the customer in question.

4. Tampering with Equipment

The Company may refuse to furnish or may deny telephone service to any person, firm or corporation on whose premises is located any telephone equipment which shows any evidence of tampering, manipulating or operation, or use of any device whatsoever, for the purpose of obtaining telephone service without payment of the charges applicable to the service rendered.

5. Use of Service for Unlawful Purposes

The service is furnished subject to the condition it will not be used for an unlawful purpose. Service will be discontinued, upon five days written notice, if any law enforcement agency, acting within its jurisdiction, advises that such service is being used or will be used in violation of law. If the Company receives other evidence giving reasonable cause to believe that such service is being or will be used, it will upon five days notice, deny the service or refer the matter to the appropriate law enforcement agency.

a. Fraud

Nebraska law prohibits the fraudulent use of a credit card or telephone billing number to obtain or attempt to obtain telephone service for the purpose of avoiding charges. The maximum penalty for violation is imprisonment for not less than one nor more than ten years.

b. Annoyance Calls

Intentional annoyance of another by telephone is prohibited by law. The maximum penalty for violation is a fine of \$100 or 90 days imprisonment or both.

B. Full Toll Denial

When a customer fails to pay outstanding charges billed by the Company for MTS calls, including MTS provided by the Company and interexchange carriers (e.g., 0+, 1+, 0-, 10XXX), all MTS service may be denied (Full Toll Denial), where Company facilities are capable of providing Full Toll Denial. Where Company facilities do not permit Full Toll Denial, the Company may deny all service.

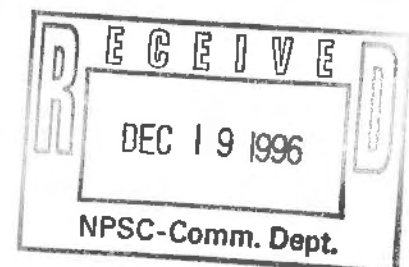

NOTICE

THE INFORMATION CONTAINED IN THIS DOCUMENT IS SUBJECT TO CHANGE.

ARAPAHOE TELEPHONE COMPANY

Exchange and Network
Services Catalog

SECTION 2

Page 11

Release 1

State of Nebraska

Notified: 12-19-96

Effective: 4-1-2018

2. GENERAL TERMS AND CONDITIONS OF OFFERING

C. Restoration of Service

1. If the service furnished a customer is temporarily suspended for nonpayment of charges due or for any other violation of the regulations of the Company, such service is restored only upon payment of a restoration of service charge in addition to charges due for service and facilities.
2. In cases where the service has been completely disconnected from a customer's premises because of discontinuance of service for nonpayment of charges due or for any other violation of the terms and conditions of the Company, service is reestablished only upon payment of the charges that would apply for a complete new installation for a new customer. Such charges are in addition to any charges due for services and facilities furnished up to the date of suspension of service.

	USOC	NONRECURRING CHARGE
• Each Restoration of Service, per account		
– Residence	NPP	\$ 30.00
– Business	NPP	\$ 30.00

3. Where Full Toll Denial has been applied to a customer's account (as specified under B., preceding), and the customer's main line service remains connected, MTS will be reestablished only upon the payment of all outstanding MTS charges. The following MTS Restoration Charge will apply.

	USOC	NONRECURRING CHARGE
• Per line	NPAPL	\$ 10.00

2.2.6 TEMPORARY SUSPENSION OF SERVICE – CUSTOMER INITIATED

A. General

Any class of exchange service may be temporarily suspended, at the request of the customer, as provided hereinafter. Service that is subject to an Initial Service Period in excess of one month may not be suspended prior to the expiration of such Initial Service Period.

B. Terms and Conditions

1. Private Branch Exchange Service

- a. Complete or partial temporary suspension of service with reduction in charges is permitted for any period of one month or more. The reduced rate is applicable only to such service, the use of which is actually suspended.

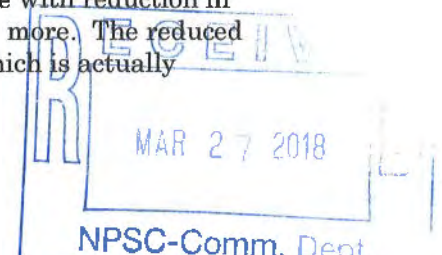

NOTICE

THE INFORMATION CONTAINED IN THIS DOCUMENT IS SUBJECT TO CHANGE.

ARAPAHOE TELEPHONE COMPANY

Exchange and Network
Services Catalog

SECTION 2

Page 12

Release 1

State of Nebraska

Notified: 12-19-96

Effective: 4-1-2018

2. GENERAL TERMS AND CONDITIONS OF OFFERING

- b. The reduction in charges for service temporarily suspended as outlined above is equal to 50% of the regular exchange charges for each item of service and facilities so suspended.
- c. If the computed rate includes a fractional part of a cent, the rate to be charged is obtained by raising or lowering the computed rate to the nearest cent. If the fractional part is one-half of a cent, the next higher cent is to be applied.

2. Main Station Service

- a. Complete temporary suspension of service is available to customers for any class of business, residence or rural individual
- b. The suspension rate will not be applicable until after the service has been in effect at full rate for a least one month.
- c. If the service suspended is restored to normal usage within 15 days, the full service rate applies for the period of suspension.
- d. If the service is suspended for a period of 16 days or longer, the reduction in charges for one or more central office lines terminating at the same location and associated supplemental service is equal to 50% of the regular exchange charge for each item of service and facilities for the period so suspended.
- e. If the computed rate includes a fractional part of a cent, the rate to be charged is obtained by raising or lowering the computed rate to the nearest cent. If the fractional part is one-half of a cent, the next higher cent is to be applied.
- f. Full service rate for one month must be applied between periods of suspension.

C. Charges

Upon request to restore service, the following nonrecurring charges apply.

	USOC	NONRECURRING CHARGE
• Per request		
– Residence	RES	\$ 30.00
– Business	RES	\$ 30.00

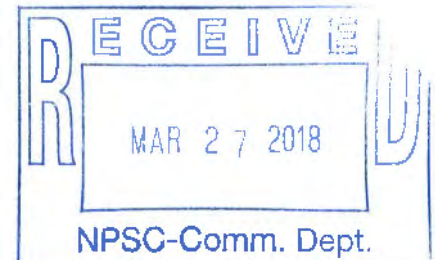

NOTICE

THE INFORMATION CONTAINED IN THIS DOCUMENT IS SUBJECT TO CHANGE.

ARAPAHOE TELEPHONE COMPANY

Exchange and Network
Services Catalog

SECTION 2

Page 13

Release 1

State of Nebraska

Notified: 12-19-96

Effective: 1-2-97

2. GENERAL TERMS AND CONDITIONS OF OFFERING

2.2.7 SPECIAL ARRANGEMENTS

- RECEIVED**
DEC 19 1996
NPSC-Comm. Dept.
- A. The rates and charges applying to telephone service and to any facilities associated therewith, contemplate standard arrangements. Special arrangements are furnished only at the customer's request. In the event that special arrangements are provided, the charges will be determined from the estimated cost of providing such arrangement.
- B. Estimated cost consists of an estimate of the following items to the extent that they are applicable:
- Cost of maintenance.
 - Cost of operation.
 - Depreciation on the estimated cost installed of any facilities provided, based on the anticipated useful service life of the facilities with an appropriate allowance for the estimated net salvage.
 - Administration, taxes, and uncollectible revenue on the basis of reasonable average charges for these items.
 - Any other specific items of expense associated with the particular situation.
 - A reasonable amount, computed on the estimated cost installed of any facilities provided, for return and contingencies.
- C. Estimated cost installed as mentioned in B., above, includes cost of materials specifically provided or used plus the estimated cost of installing, including engineering, labor, supervision, transportation, rights-of-way, and any other items which are chargeable to the capital accounts.

2.2.8 TERMINATION OF SERVICE

- A. Initial Service Periods
1. The initial service period for service and facilities is one month, except as otherwise specified.
 2. Initial service periods for service or facilities of any class will be greater than those specified herein whenever that is required in order for the Company to protect itself from making a hazardous investment because the customer's location or the character of the service required is such that upon termination of the customer's contract the facilities which have been constructed or installed to render the service are not likely to be useful for furnishing service to any other customer.
 3. Initial service periods may be less than those specified herein whenever the Company, at its discretion, deems it appropriate other than for Basic Local Exchange Services or Message Telecommunications Services.

NOTICE

THE INFORMATION CONTAINED IN THIS DOCUMENT IS SUBJECT TO CHANGE.

ARAPAHOE TELEPHONE COMPANY

Exchange and Network
Services Catalog

SECTION 2

Page 14

Release 1

Effective: 1-2-97

State of Nebraska
Notified: 12-19-96

2. GENERAL TERMS AND CONDITIONS OF OFFERING

4. Service for which the initial service period is one month may be terminated prior to the expiration of such period only by payment of charges for the entire initial period. The charges for any supplemental item of service or facilities furnished in connection with such service shall, however, be terminated in accordance with the conditions applicable to that item of service or facilities.
5. No charge is made for discontinuing any or all of the service or facilities furnished a customer, provided the initial service period for the service or facilities to be discontinued has expired and that any minimum charges for items of service or facilities have been paid in full.

B. Termination Liability/Waiver Policy

Services provided via service agreements may be subject to the Termination Liability/Waiver Policy. This policy applies only to services that specifically reference this Termination Liability/Waiver Policy in their respective section of this Catalog.

1. Definitions

Minimum Billing Level

When services are provided under a service agreement, a Minimum Billing Level will be established for use in calculating discontinuance charges. The Minimum Billing Level is 100% of the total monthly rates for the service provided under the customer's service agreement, unless otherwise specified.

Minimum Service Period

When services are provided under a service agreement, a Minimum Service Period may be established. This would be the period of time that the 100% factor of the Termination Liability Charge would apply.

2. Complete Disconnect

If the customer chooses to completely discontinue service, at any time during the term of the agreement, a termination charge will apply, unless the customer satisfies the conditions specified in the Waiver Policy. The termination charge is 100% of the Minimum Service Period, if applicable, and 15% of the Minimum Billing Level for the remaining term of the agreement.

- For example, if the customer discontinues service after 17 months of a 3-year (36 month) agreement, the termination charge will be the Minimum Billing Level for the service multiplied by 15%, multiplied by 19 months.
- If the customer discontinues service after 6 months of a 3-year (36 month) agreement, with a 1-year (12 months) Minimum Service Period, the Termination Charge will be 100% of the Minimum Billing Level for the remaining 6 months of the Minimum Service Period plus 15% of the Minimum Billing Level multiplied by 24 months.

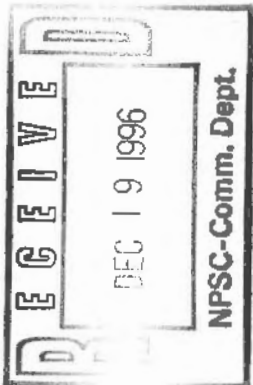

NOTICE

THE INFORMATION CONTAINED IN THIS DOCUMENT IS SUBJECT TO CHANGE.

ARAPAHOE TELEPHONE COMPANY

Exchange and Network
Services Catalog

SECTION 2

Page 15

Release 1

Effective: 1-2-97

State of Nebraska

Notified: 12-19-96

2. GENERAL TERMS AND CONDITIONS OF OFFERING

3. Partial Disconnect

If the customer discontinues a portion of their service, and that causes the customer's monthly billing level to fall below the Minimum Billing Level of the agreement, a termination charge will apply to the portion of the service agreement that is below the Minimum Billing Level.

4. Waiver Policy

A termination charge will be waived when the customer discontinues their contracted service(s), provided all of the following conditions are met:

- The customer signs a new service agreement for any other Company provided service(s);
- Both the existing and the new service(s) are provided solely by the Company;
- The order to discontinue the existing service(s) and the order to establish the new service(s) are received by the Company at the same time;
- The new service(s) installation must be completed within 30 calendar days of the disconnection of the old service(s), unless the installation delay is caused by the Company;
- The total value of the new service agreement(s), excluding any special construction charges and any other nonrecurring charges, is equal to or greater than 115% of the remaining value of the existing agreement(s);
- A new minimum service period goes into effect when the new service agreement term begins;
- The customer agrees to pay any previously billed, but unpaid recurring, and any outstanding nonrecurring charges. These charges cannot be included as part of the new service agreement;
- All applicable nonrecurring charges will be assessed for the new contracted service(s).

2.3 PAYMENT FOR SERVICE

2.3.1 CUSTOMER RESPONSIBILITY

The customer is responsible for payment of all charges for facilities and services furnished at the customer's request, including charges for long distance services originated, or charges accepted, at such facilities. Bills are due when rendered and are payable at any business office of the Company, or at any other location designated by the Company. Failure to receive a bill does not exempt the customer from prompt payment of the account.



NOTICE

THE INFORMATION CONTAINED IN THIS DOCUMENT IS SUBJECT TO CHANGE.

ARAPAHOE TELEPHONE COMPANY

Exchange and Network
Services Catalog

SECTION 2

Page 16

Release 1

State of Nebraska

Notified: 12-19-96

Effective: 4-1-2018

2. GENERAL TERMS AND CONDITIONS OF OFFERING

2.3.2 PAYMENT OF BILLS

A. Rendering of Payment

1. Late Payment Charge

- a. A charge, at a rate not to exceed rates established by law, applies to unpaid amounts of \$15.01 or more. The charge on the unpaid amount of the account will be computed from the date of billing unless the account is fully paid within 30 days from that date. The date of billing shall mean the date the customer's bill is prepared by the Company. The 30 day period may be extended or changed by an agreement in writing.
- b. Collection procedures and the requirement for a deposit are unaffected by the application of a late payment charge.
- c. The late payment charge does not apply to final bills, one-time miscellaneous bills, bills rendered or mailed late, or first month bills for a telephone number change.
- d. The late payment charge does not apply to unpaid balances associated with disputed amounts. Undisputed amounts on the same bill shall be subject to the late payment charge.

2. Returned Check Charge

An administrative charge is applicable to the customer's account for each occasion that a check, bank draft, or an electronic funds transfer item is returned to the Company for the reason of insufficient funds or no account

CHARGE

- Returned Check Charge \$35.00

2.3.3 ADVANCE PAYMENTS

- A. Except as hereinafter provided, applicants for telephone service are required to pay in advance, at the time the application is made, any nonrecurring charges or installation charges applicable, and to pay the charges for one billing period for exchange service and facilities ordered.
- B. Where charges for construction apply, such charges are collected in advance if circumstances made that advisable in order to safeguard the Company's revenue. In such cases, and in cases where installation and/or nonrecurring charges are based on the cost of labor and material required, any advance payments are estimated and any adjustments which may be necessary are made when the work is completed.
- C. Advance payments are not required for service furnished customers whose financial responsibility is a matter of general knowledge. This also applies to Federal, State, County and Municipal governments.

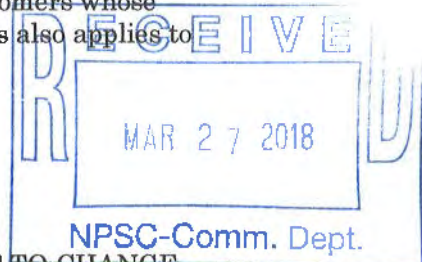

NOTICE

THE INFORMATION CONTAINED IN THIS DOCUMENT IS SUBJECT TO CHANGE.

ARAPAHOE TELEPHONE COMPANY

Exchange and Network
Services Catalog

SECTION 2

Page 17

Release 1

State of Nebraska

Notified: 12-19-96

Effective: 1-2-97

2. GENERAL TERMS AND CONDITIONS OF OFFERING

2.3.4 DEPOSITS

A. Deposit Requirements

1. Applicants for service unable to establish a satisfactory credit rating with the Company or existing customers whose credit rating has become impaired will be required to make a suitable cash deposit to be held as security for the payment of bills for telephone service.
2. The amount of such deposit shall not exceed the amount of charges for telephone service which it is estimated will accrue for a period of two months.
3. When service is terminated, any balance of the amount deposited remaining after deduction of all sums due the Company will be returned to the customer, or the deposit may be returned at anytime previous thereto at the option of the Company.

B. Interest on Deposits

Interest at the rate of 7% per annum, will be paid on all deposits.

C. Deposit Alternatives

A Deposit Alternative may be available to residential service applicants. Residential customers may choose to subscribe to an individual exchange access line for local calling in lieu of a deposit for a full service arrangement. The access line is equipped with Toll Restriction and Billed Number Screening.

2.4 LIMITATIONS OF LIABILITY

2.4.1 LIMITATIONS

- A. The services furnished by the Company, in addition to the limitations set forth herein, are subject to the following limitations: The Company shall not be liable for damage arising out of mistakes, omissions, interruptions, delays, errors or defects in transmission or other injury, including but not limited to injuries to persons or property from voltages or currents transmitted over the service of the Company, caused by customer-provided equipment (except where a contributing cause is the malfunctioning of a Company-provided connecting arrangement, in which event the liability of the Company shall not exceed an amount equal to a proportional amount of the Company billing for the period of service during which such mistake, omission, interruption, delay, error, defect in transmission or injury occurs).
- B. The Company's liability, if any, for its willful misconduct is not limited by this Catalog. With respect to any other claim or suit, by a customer or by any others, for damages associated with the installation, provision, preemption, termination, maintenance, repair, or restoration of service, the Company's liability, if any, shall not exceed an amount equal to the proportionate part of the monthly recurring charge for service for the period during which the service was affected. This liability shall be in addition to any amounts that may otherwise be due the customer under this Catalog as an allowance for interruptions.

NOTICE

THE INFORMATION CONTAINED IN THIS DOCUMENT IS SUBJECT TO CHANGE.



ARAPAHOE TELEPHONE COMPANY

Exchange and Network
Services Catalog

SECTION 2

Page 18

Release 1

Effective: 1-2-97

State of Nebraska

Notified: 12-19-96

2. GENERAL TERMS AND CONDITIONS OF OFFERING

C. Defacement of Premises

The Company is not liable for any defacement or damage to the customer's premises resulting from the existence of the Company's facilities on such premises, or from the installation or removal thereof, when such defacement or damage is not the result of the negligence of the Company.

D. Transmission of Messages

The function of the Company is to furnish means of communication between telephone stations. Acceptance, by employees, of written or verbal communications from the public, for transmission or delivery, is forbidden.

E. Outgoing and Incoming Service Privileges

The Catalogs of the Company govern and fix the outgoing service of a customer and in no manner guarantee the same incoming service. All incoming service of a customer depends upon and is limited by the right of a calling customer to such service.

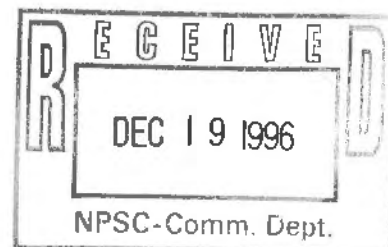

NOTICE

THE INFORMATION CONTAINED IN THIS DOCUMENT IS SUBJECT TO CHANGE.

ARAPAHOE TELEPHONE COMPANY

Exchange and Network
Services Catalog

SECTION 2

Page 19

Release 1

Effective: 1-2-97

State of Nebraska

Notified: 12-19-96

2. GENERAL TERMS AND CONDITIONS OF OFFERING

2.5 RESPONSIBILITIES OF PARTIES

2.5.1 COMPANY RESPONSIBILITY

A. Maintenance and Repair

Except under conditions involving their outright sale, facilities furnished by the Company on the premises of a customer, authorized user or agent of the Company, are the property of the Company. They are provided upon the condition that such facilities must be installed, relocated, rearranged, tested, inspected and maintained by the Company, and that the Company's employees and agents may enter said premises at any reasonable hour for such purposes and to make collection from coin-box telephones or, upon termination or cancellation of the service, to remove such facilities.

B. Performance of Work on Customers' Premises

1. It is contemplated that all work on customers' premises can be performed during regular working hours. If a customer requests that work be performed during hours which results in overtime or premium rates of pay, a charge may apply in addition to other rates and charges which may be applicable, equal to the amount of overtime or premium time payments.
2. It is also contemplated that all installation, removals, service connections, moves and changes requested by a customer be performed without the Company incurring unusual costs. If a customer requests that work be performed in a special manner or at a special time which results in unusual costs, a charge equal to the amount of unusual costs may apply in addition to other applicable rates and charges.

All ordinary expense of maintenance and repair, unless otherwise specified in the Company's Catalogs or in the contract for the use of the facilities will be borne by the Company.

- a. The telephone facilities furnished shall be carefully used and cared for by the customer and shall be surrendered to the Company upon termination of the customer's right of use, in as good a condition as when received, ordinary wear and tear excepted.
- b. In case of damage to, or destruction of, any of the said facilities, due to negligence or willful act of the customer, the customer shall pay either the cost of replacing the facility or the cost of restoring the facility to its original condition.

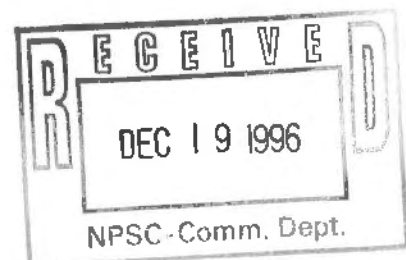

NOTICE

THE INFORMATION CONTAINED IN THIS DOCUMENT IS SUBJECT TO CHANGE.

ARAPAHOE TELEPHONE COMPANY

Exchange and Network
Services Catalog

SECTION 2

Page 20

Release 1

Effective: 1-2-97

State of Nebraska

Notified: 12-19-96

2. GENERAL TERMS AND CONDITIONS OF OFFERING

2.5.2 CUSTOMER RESPONSIBILITY

A. Transmission of Messages

The customer indemnifies and saves the Company harmless against claims for libel, slander, infringement of copyright arising from the use of material transmitted over its facilities, or infringement of patents arising from combining with or using in connection with, facilities of the Company, apparatus or systems of the customer; and against all other claims arising out of any act or omission of the customer in connection with facilities provided by the Company.

B. Protection of Equipment and Facilities

Customers shall protect the facilities of the Company used to render the service to them and located upon their premises and grounds against other users and uses of their property. When, in the judgment of the Company, such other users or uses would impair any Company service or constitute a hazard to Company property or to the safety of its employees, special precautions may be required.

C. Lost and Damaged Equipment

Customers of the Company will be responsible for loss of or willful damages to, facilities provided by the Company for use by customers on their premises.

D. Building Space and Electric Power Supply

Suitable commercial power, power wiring and outlets, housing, heat, light and ventilation and conduit as required for the operation of telephone facilities furnished for the use of customers in or on their premises and grounds shall be provided, i.e., furnished, installed and maintained by and at the expense of the customer.

2.5.3 COMMUNICATIONS SYSTEMS AND PREMISES WIRE

A. Connections of Equipment, Communications Systems and Premises Wire

No equipment, apparatus, circuit or device not furnished by the Company shall be attached to or connected with the facilities furnished by the Company, whether physically, by induction or otherwise, except as provided in the Company's Catalogs. In case any such unauthorized attachment or connection is made, the Company will have the right to remove or disconnect the same; or suspend the service during the continuance of said attachment or connection; or to terminate the service.

B. Broadcast of Recorded Telephone Conversations

Recorded telephone conversations may be broadcast either during or following the period of recording, provided that in the interest of protecting the privacy of telephone service the recording is made in accordance with the conditions set forth in the Catalogs of the Company governing the recording of telephone conversation.

NOTICE

THE INFORMATION CONTAINED IN THIS DOCUMENT IS SUBJECT TO CHANGE.

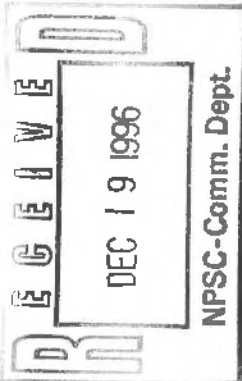

ARAPAHOE TELEPHONE COMPANY

Exchange and Network
Services Catalog

SECTION 2

Page 21

Release 2

State of Nebraska

Notified: 06-15-2012

Effective: 04-01-2018

2. GENERAL TERMS AND CONDITIONS OF OFFERING

2.6 SPECIAL TAXES, FEES AND CHARGES

A. When any municipality, other political subdivision or local agency of government collects from the Company a gross receipts tax, occupation tax, license tax, permit fee, or franchise fee, such taxes and fees shall, insofar as practicable, be billed pro rata to the exchange customers receiving service within the territorial limits of such municipality, other political subdivision or local agency of government.

B. Communication Impaired Surcharge

Nebraska law requires that a surcharge be collected on each telephone access line in Nebraska. The surcharge will be remitted to the Nebraska Public Service Commission to establish and administer a fund for a statewide Dual Relay System to be used for eligible communication impaired persons.

This surcharge will be collected on the first one-hundred (100) telephone access lines per customer, and will appear on a customer's local telephone bill.

	USOC	MONTHLY RATE
• Surcharge per access line	AH8	\$0.01

C. Access Recovery Charge

Changes to the Universal Service and Intercarrier Compensation Rules have resulted in the elimination of certain fees and the implementation of new fees. The Access Recovery Charge is a new recurring fixed charge billed directly to end users as follows:

	MONTHLY RATE
• Residential customers (does not apply to Lifeline/NTAP customers)	\$0.50
• Single line business customers	\$0.50
• Multi-line business customers	\$1.00

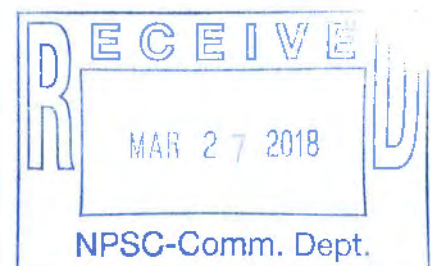

NOTICE

THE INFORMATION CONTAINED IN THIS DOCUMENT IS SUBJECT TO CHANGE.

ARAPAHOE TELEPHONE COMPANY

Exchange and Network
Services Catalog

SECTION 3

Index Page 1

Release 1

Effective: 1-2-97

State of Nebraska

Notified: 12-19-96

3. SERVICE CHARGES

SUBJECT	PAGE
Dual Service.....	6
Miscellaneous Nonrecurring Charges.....	1
Nonrecurring Charges	1
Premises Work Charges.....	6
Service Connection Charge.....	5

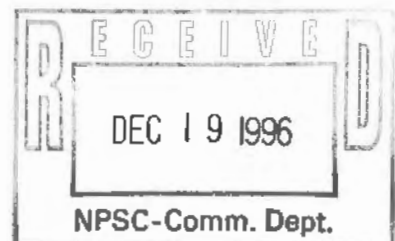

ARAPAHOE TELEPHONE COMPANY

Exchange and Network
Services Catalog

SECTION 3

Page 1

Release 1

Effective: 1-2-97

State of Nebraska
Notified: 12-19-96

3. SERVICE CHARGES

3.1 MISCELLANEOUS NONRECURRING CHARGES

3.1.1 NONRECURRING CHARGES

A. Description

A nonrecurring charge is a one-time charge made under certain conditions to connect, move and change telephone service.

Nonrecurring charges, where applicable, are specified with services as stated in each section of this Catalog unless otherwise specified or included in this section.

B. Definitions

Amending Customer Request

A subsequent request to change the order, providing the changes can be accomplished without issuance of new work orders, and all work ordered can still be completed at the same time.

Change

When telephone service is changed at the customer's request. Such changes include, but are not limited to, the following:

- Change in class, grade or type of service.

Class of Service

Residence, business, or coin telephone service.

Complex Service

For the purpose of applying Premises Work Charges, this is any telephone system which is served through common equipment.

Customer Request

The contact (call visit or correspondence) during which the customer provides sufficient information to effect service order work.

Firm Bid

A firm price, in writing for a stated purpose, good for a limited period of time. Firm bids accepted by customers will be billed at the stated price, regardless of the actual cost incurred by the installation forces.

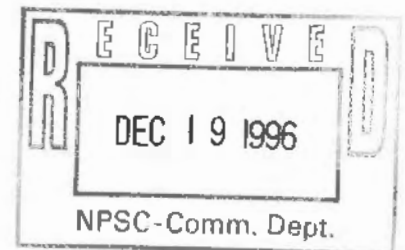

NOTICE

THE INFORMATION CONTAINED IN THIS DOCUMENT IS SUBJECT TO CHANGE.

ARAPAHOE TELEPHONE COMPANY

Exchange and Network
Services Catalog

SECTION 3

Page 2

Release 1

Effective: 1-2-97

State of Nebraska

Notified: 12-19-96

3. SERVICE CHARGES

Grade of Service

1-party or rural service and flat rate or measured lines.

Installation Charge

A charge designed to recover nonrecurring costs associated with the installation of services.

Move

A relocation of telephone service within a customer's premises.

Network Interface

The point of connection with the Telecommunication Network which is located inside the customer's premises at a place deemed necessary by the Company in order to insure transmission quality and which is readily accessible to the customer.

Noncomplex Service

For the purpose of applying Premises Work Charges, this is any telephone system not requiring common equipment.

Premises Work Charge

For all customer requested work performed by the Company on the customer's premises. Premises Work Charges do not apply to:

- Establish or reestablish network access.
- Installation of wire and appropriate jack on the network side of the Network Interface.

Product Charge

A charge designed to recover additional nonrecurring costs for services not covered by Premises Work Charges.

Service

An arrangement of telephone facilities located on a customer's premises, separate and independent from an arrangement at other premises.

Type of Service

Rotary dial or touch-tone service.

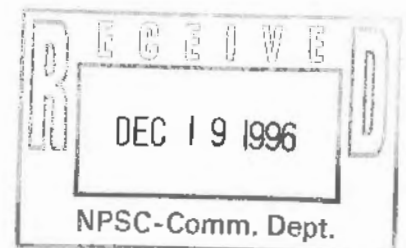

NOTICE

THE INFORMATION CONTAINED IN THIS DOCUMENT IS SUBJECT TO CHANGE.

ARAPAHOE TELEPHONE COMPANY

Exchange and Network
Services Catalog

SECTION 3

Page 3

Release 1

Effective: 1-2-97

State of Nebraska
Notified: 12-19-96

3. SERVICE CHARGES

C. Terms and Conditions

1. Nonrecurring charges apply to customer-initiated requests to establish telephone service except as specified in this or in other sections of this Catalog.
 - a. Charges to establish business main and additional service (including semipublic), residence main and additional service trunks, and lines, consist of:
 - Nonrecurring charges for appropriate class of service.
 - Premises Work Charges where applicable.
 - b. For installation of miscellaneous services subject to an installation or product charge the following charges apply:
 - Nonrecurring charges for appropriate class of service.
 - Premises Work Charges where applicable.
2. Nonrecurring charges apply for customer-initiated requests to move telephone service on the same premises. Charges for moves of trunks, business (including semipublic) and residence service consist of:
 - Nonrecurring charges for appropriate class of service.
 - Premises Work Charges where applicable.For moves of other services subject to an installation or product charge, apply:
 - The appropriate nonrecurring charge.
 - Any appropriate Premises Work Charges.
 - The installation or product charge or specifically described move charge shown in other sections of this Catalog.
3. Nonrecurring charges apply for customer-initiated requests for changes. Nonrecurring charges apply as follows unless specifically excepted in other sections of this Catalog:
 - Apply nonrecurring charges for appropriate class of service.
 - Apply Premises Work Charges where applicable.
4. Nonrecurring charges apply separately to each unit of service moved or changed, except where the applicable charge is the actual cost of all moves, changes or rearrangements made at one time.



NOTICE

THE INFORMATION CONTAINED IN THIS DOCUMENT IS SUBJECT TO CHANGE.

ARAPAHOE TELEPHONE COMPANY

Exchange and Network
Services Catalog

SECTION 3

Page 4

Release 1

State of Nebraska
Notified: 12-19-96

Effective: 1-2-97

3. SERVICE CHARGES

5. If work involves both business and residence items of service, the appropriate class of service nonrecurring charge applies for each.
6. One nonrecurring charge applies per customer request to suspend and restore service.
7. "Amending Customer Requests" are not subject to additional nonrecurring charges.
8. One nonrecurring charge applies for the service located at a premises. No additional nonrecurring charge applies for off-premises or secondary locations.
9. Conditions Under Which Nonrecurring Charges Do Not Apply
 - a. Nonrecurring charges do not apply for Company initiated work:
 - (1) Public telephone service.
 - (2) Telephone service located on a customer's premises but used exclusively by the Company for maintenance or training activities.
 - (3) To move or change customer's telephone service, up to and including the Network Interface or its equivalent, if required or initiated by the Company.
 - (4) Disconnection of service for nonpayment of charges due. The charge applicable for restoral of service is specified in 2.2.5.
 - (5) To eliminate flat rate abuse.
 - b. Nonrecurring charges do not apply for the following customer-initiated requests providing work is limited to that specified below:
 - (1) Complete termination of service.
 - (2) The "From" portion of work involved in a transfer of service from one to another premises.
 - (3) Work done on the central office line to change from flat rate service to another grade of service.
 - (4) The reestablishment of network service following destruction of a customer's premises or a portion thereof resulting from explosion, fire, flood, storm, accident, or the action of a public enemy. In such cases, and when possible, service up to and including the Network Interface will be reestablished at one location without nonrecurring charges or installation charges. At the customers option, the reestablished service may be at the immediately occupied location or a subsequently occupied location.



NOTICE

THE INFORMATION CONTAINED IN THIS DOCUMENT IS SUBJECT TO CHANGE.

ARAPAHOE TELEPHONE COMPANY

Exchange and Network
Services Catalog

SECTION 3

Page 5

Release 1

Effective: 1-2-97

State of Nebraska

Notified: 12-19-96

3. SERVICE CHARGES

- (5) Disconnection and/or removal of the following items of service, providing no other work subject to nonrecurring charges is involved:
- Main or additional telephone lines.
 - Directory listings and directory services.
- (6) Establishing, changing, or discontinuing arrangements for:
- Calling Card
 - Tele-Check Plan
 - Mail Bill Address Arrangements
 - Other Special Billing Arrangements
- (7) Cancellation of orders except as specified in Section 2.
- (8) Changing to a telephone compatible with aids used by the hearing handicapped from a telephone which cannot be made compatible by changes in component parts.
- (9) Changing responsibility, provided that service and billing is continuous and no final bill is issued.
- (10) Changes to or from touch-tone, ESS, Rotary, or changes in Custom Calling Services provided on individual line service, or changes to or from Rotary or hunting, or Hunting to Hunting.

D. Rates and Charges

A Service Connection Charge is a charge associated with connecting or moving residence exchange access lines and features or services (where appropriate) which are added and/or changes concurrent with the access line activity.

- Per Service Order

SERVICE CONNECTION CHARGE

\$ 33.00

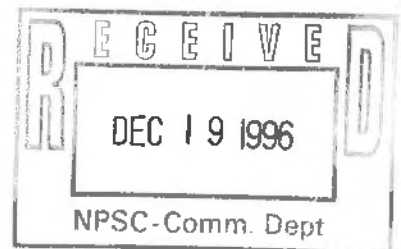

ARAPAHOE TELEPHONE COMPANY

Exchange and Network
Services Catalog

SECTION 3

Page 6

Release 1

Effective: 1-2-97

State of Nebraska

Notified: 12-19-96

3. SERVICE CHARGES

3.1.2 PREMISES WORK CHARGES

A. Charges

NONRECURRING CHARGE

- Schedule I

Applicable to work performed Monday through Friday between 8:00 a.m. and 5:00 p.m.

- Initial Premises Work Charge, applies for the first 15 minutes or fraction thereof of billable premises work. \$ 21.50
- Additional Premises Work Charge, applies for each additional 15 minutes or fraction thereof. 9.00

3.1.3 DUAL SERVICE

A. Description

Dual Service provides exchange access line service with the same telephone number simultaneously to two different addresses served from the same wire center. Dual Service is designed to provide the customer continuous service at both locations during the time of a move.

B. Terms and Conditions

1. Dual Service is available to those services that are not specially designed or engineered.
2. Dual Service is furnished only in central offices where adequate and suitable facilities are available.
3. Dual Service is available for a maximum of 30 days.
4. Dual Service is available on orders for a transfer of service within the same wire center where no telephone number change is involved.

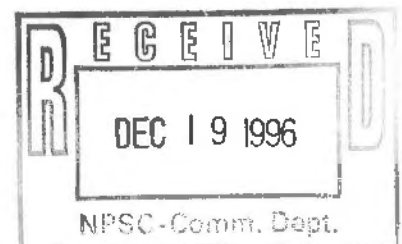

NOTICE

THE INFORMATION CONTAINED IN THIS DOCUMENT IS SUBJECT TO CHANGE.

ARAPAHOE TELEPHONE COMPANY

Exchange and Network
Services Catalog

SECTION 3

Page 7

Release 1

Effective: 1-2-97

State of Nebraska

Notified: 12-19-96

3. SERVICE CHARGES

C. Rates and Charges

1. This service is subject to the terms and conditions, rates and charges applicable to other exchange services and is in addition to basic rates and charges for the service with which it is associated.
2. In addition to the nonrecurring charges listed below, the customer will be charged the appropriate portion of the monthly rates for services provided at both locations during the period of Dual Service.

	USOC	NONRECURRING CHARGE
• Residence, per line	CBU	\$ 33.00
• Business, per line or trunk	CBU	33.00

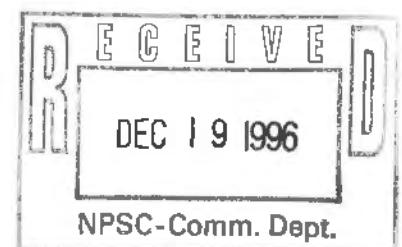

NOTICE

THE INFORMATION CONTAINED IN THIS DOCUMENT IS SUBJECT TO CHANGE.

ARAPAHOE TELEPHONE COMPANY

Exchange and Network
Services Catalog

SECTION 4
Index Page 1
Release 1
Effective: 1-2-97

State of Nebraska
Notified: 12-19-96

4. CONSTRUCTION CHARGES AND OTHER SPECIAL CHARGES

SUBJECT	PAGE
Extensions for New Real Estate Additions.....	2
General.....	1
Unusual Installations	2

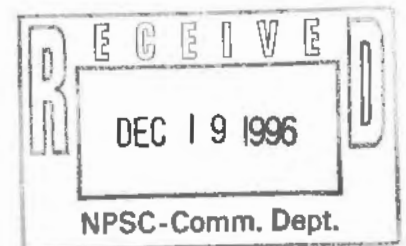

NOTICE
THE INFORMATION CONTAINED IN THIS DOCUMENT IS SUBJECT TO CHANGE.

ARAPAHOE TELEPHONE COMPANY

Exchange and Network
Services Catalog

SECTION 4

Page 1

Release 1

State of Nebraska

Notified: 12-19-96

Effective: 1-2-97

4. CONSTRUCTION CHARGES AND OTHER SPECIAL CHARGES

4.1 GENERAL

A. Description

All rates and charges quoted in Section 5 of this Catalog and in other sections of this Catalog provide for the furnishing of associated channel equipment or facilities where plant facilities are available or when the construction of the necessary facilities does not involve unusual costs. Likewise the rates and charges quoted in this Catalog contemplate the use of associated channel equipment and wiring of standard type and finish.

Under certain conditions, in other sections of this Catalog, construction charges are made to cover all or a portion of the unusual costs involved in the establishment of service, in addition to the rate for the class of service furnished, and any nonrecurring charges, mileage charges, or other charges that may apply. Also, where special arrangements or assemblies of associated channel equipment or wiring are desired, special charges are made as indicated.

B. Terms and Conditions

1. If the customer desires, he may furnish labor or material, or both, as part or whole payment for construction charges for pole or wire construction outside of base rate areas of exchanges, provided the labor and material furnished are in conformity with the Company's specifications.
2. When attachments are made to poles of other companies in lieu of providing pole line construction for which the customer regularly would be charged, the cost to the Company for such attachments must be borne by the customer.
3. "Cost", as used in this section, is to be interpreted to mean the cost of labor and material, plus the same proportion of the Company's general operating and supervisory expenses as is applied in the Company's accounts.
4. Except as otherwise provided, all construction is owned and maintained by the Company.
5. If, to serve a customer, it is necessary to use right-of-way on private property, the customer is required to provide, or pay the cost of providing the necessary right-of-way without expense to the Company. Provision and cost of right-of-way is, however, assumed by the Company whenever it is evident that the construction for which the right-of-way is obtained will be required as a part of the properly designed telephone distribution system used for serving customers in the area in which the right-of-way is obtained or beyond such area. If service can be provided by means of construction on a public highway without unusual cost, but the Company elects to provide construction on private property, the cost of obtaining necessary right-of-way in connection with such private property construction is not charged to the customer or customers so served.

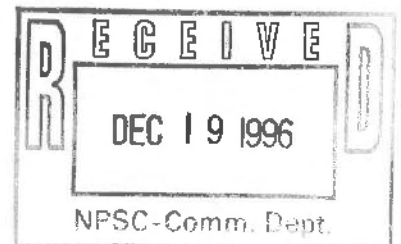

NOTICE

THE INFORMATION CONTAINED IN THIS DOCUMENT IS SUBJECT TO CHANGE.

ARAPAHOE TELEPHONE COMPANY

Exchange and Network
Services Catalog

SECTION 4

Page 2

Release 1

State of Nebraska

Notified: 12-19-96

Effective: 1-2-97

4. CONSTRUCTION CHARGES AND OTHER SPECIAL CHARGES

6. If a special type of construction is desired by a customer, as when underground service connections are desired in places where aerial drop wires would ordinarily be used to reach customers' premises, or if the unusual requirements of a customer make the cost of an installation higher than it would be if the usual type of construction were used, the customer is required to bear the difference in cost between the special type of construction and the average cost of the usual type of construction.
7. Ordinarily business buildings such as office buildings, stores, and factories are equipped with suitable conduit, wire wells or pipes in which to run the wiring and cabling for providing telephone service to customers occupying such buildings. Where buildings are not so equipped, the customer is required to bear such of the costs involved in installing the interior wiring or cabling necessary to provide the service desired as are in excess of what they would be if the buildings were so equipped. Likewise, where, in providing service in residences, the cost of providing the inside wiring desired is excessive, as may be the case where it is necessary to run wires through walls of masonry, the customer is required to bear the excessive costs involved.

4.2 UNUSUAL INSTALLATIONS

4.2.1 EXTENSIONS FOR NEW REAL ESTATE ADDITIONS

A. Facility Charges for New Areas of Land Development

1. A facility charge (refundable in accordance with 4., following) is payable by the Developer when the Company undertakes the provision of feeder and distribution facilities for exchange service to an area of six or more lots being developed under a definite plan.
2. When facility charges apply, the estimated cost of the facilities requested is payable in full by the Developer prior to the start of any facility placement by the Company.

The Company will not incur expenses prior to receiving payment or payments from the Developer equal to the amount of the estimated expenditures.

The facility charge will be adjusted to actual cost upon completion of the construction; at that time, an additional charge or refund will be rendered to the Developer.

3. The term "Cost," as used in this section of the Catalog means the cost of equipment, material, labor, engineering, supervision, transportation, rights-of-way and other items chargeable to the capital accounts and where related, (1) the cost of moving, rearranging or removing equipment or materials, with an appropriate allowance for any salvage value of recovered items and (2) the cost of maintenance and taxes plus an appropriate amount for depreciation, overheads, post tax income, contribution and contingencies.

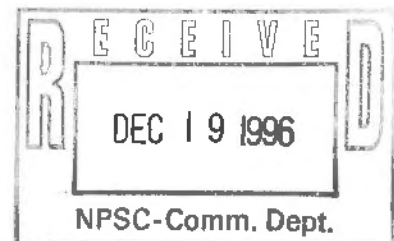

NOTICE

THE INFORMATION CONTAINED IN THIS DOCUMENT IS SUBJECT TO CHANGE.

ARAPAHOE TELEPHONE COMPANY

Exchange and Network
Services Catalog

SECTION 4

Page 3

Release 1

State of Nebraska

Notified: 12-19-96

Effective: 1-2-97

4. CONSTRUCTION CHARGES AND OTHER SPECIAL CHARGES

4. The Company and the Developer will enter into a written facilities provision agreement covering a time period not to exceed five years for provision of the requested facilities. The agreement will include the following:
 - a. A description of the development.
 - b. The number of lots within the development during the contract period.
 - c. A description of the telephone facilities determined by the Company to be provided for the estimated telephone demand during the contract period.
 - d. The amount of the estimated facility charge.
 - e. A provision for an annual refund without interest to be made each year in the anniversary month of the agreement. The refund will be determined as follows:
 - (1) The facility charge set forth in 2., preceding, will be prorated on actual cost to each of the lots specified in the agreement between the Developer and the Company.
 - (2) On each anniversary date of the agreement, the annual net increase of completed structures on lots will be determined.
 - (3) The annual refund will be an amount equal to the multiple of the prorated amount provided in (1), above, and the net annual completed structures in the development. After the initial refund, subsequent refunds shall be given only for those completed structures on lots in excess of the number at the end of the preceding period in which a refund was given.
 - (4) Refund will not be made for lots in excess of the total number specified in the agreement.
5. At the end of the contract period, any balance not refunded pursuant to 4.e., preceding, becomes the property of the Company and is nonrefundable.
6. At the option of the developer, \$200.00 for each lot in the development may be paid on a nonrefundable basis in lieu of the above.
7. Where the Developer makes no arrangements for facilities to and within a development, a prorated facility charge will apply to individual applicants, on a nonrefundable basis, when they apply for telephone service within the development. The Company reserves the right to determine when facility charges for new areas of land development will apply.

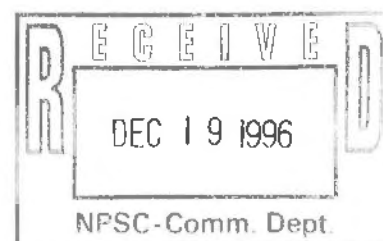

NOTICE

THE INFORMATION CONTAINED IN THIS DOCUMENT IS SUBJECT TO CHANGE.

ARAPAHOE TELEPHONE COMPANY

Exchange and Network
Services Catalog

SECTION 4

Page 4

Release 1

Effective: 1-2-97

State of Nebraska

Notified: 12-19-96

4. CONSTRUCTION CHARGES AND OTHER SPECIAL CHARGES

8. At the option of the Developer, no facility charges need to be paid by the Developer prior to the start of any facility placement by the Company if the Developer enters into a written agreement with the Company that includes the following provisions:

- a. A description of the development.
- b. The number of lots within the development.
- c. A provision that the Developer shall cause a declaration of covenants pertaining to each and every lot in the development to be filed with the register of deeds in the county where the development is located which contains a notice of charge for telecommunications facilities furnished to that development. Such notice shall state that should construction not be commenced on any lot covered by the declaration within five years from the date the Company files a document with the register of deeds giving notice that installation of the feeder and distribution facilities for that development has been completed, then each such unimproved lot shall be subject to a facility charge payable to the Company or its successors in the amount of \$450.00. Such facility charge shall be due and owing immediately upon the expiration of the five year period, and if such charge is not paid within 60 days after the sending of written notice by the Company or its successors to the owner of an unimproved lot that such charge is due, then said charge will begin drawing interest commencing upon the expiration of the 60-day period at the rate of 12% per annum or the maximum rate allowed by law if said maximum is less than 12% per annum at that time.

Such facility charge shall be void and nonassessable in the event construction shall have commenced on at least 90% of the lots covered by such declaration of covenants within five years from the date the Company filed its documents with the register of deeds giving notice that the facilities had been installed.

- d. A provision that if 90% of the lots in the development are not improved within five years from the date the feeder and distribution facilities are installed in the development, then the owner at that time of any unimproved lot shall owe the Company \$450.00 for each lot that is unimproved in payment for the Company's unused facilities. A lot shall be considered unimproved if construction of a permanent structure has not commenced on that lot. Construction shall be considered as having commenced if a footing inspection has been made on the lot in question by officials of the city or other appropriate governmental body.
9. When the nature of a development is such that additional central office facilities must be provided specifically to serve the development, additional charges may apply to the Developer based on the nonrecoverable, nonreusable costs involved and be included in a contractual agreement.
10. The Company will use its best effort to assure the availability of central office facilities consistent with its obligations to provide exchange service.

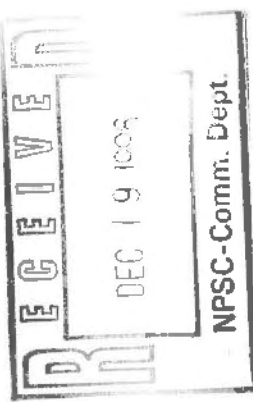

NOTICE

THE INFORMATION CONTAINED IN THIS DOCUMENT IS SUBJECT TO CHANGE.

ARAPAHOE TELEPHONE COMPANY

Exchange and Network
Services Catalog

SECTION 5

Index Page 1

Release 1

Effective: 1-2-97

State of Nebraska

Notified: 12-19-96

5. EXCHANGE SERVICES

SUBJECT	PAGE
Coinless Public Telephone Service.....	21
Custom Calling Services.....	13
Customer Number Service.....	33
Directory Assistance.....	37
Directory Listings.....	26
EAS Group.....	1
Exchange Areas.....	1
Extended Area Service.....	1
Flat Rate Service.....	9
Hunting Service.....	10
Intercept-Services.....	35
Lifeline.....	12
Link Up Nebraska.....	11
Local Calling Areas.....	1
Measured Service.....	2
Operator Verification Service.....	40
Public Access Line (PAL) Service.....	21
Public Telephone Service.....	16
Semipublic and Shared Payphone Service.....	17
Special Reversed Charge Service.....	38
Zoned Service.....	1

NOTICE

THE INFORMATION CONTAINED IN THIS DOCUMENT IS SUBJECT TO CHANGE.

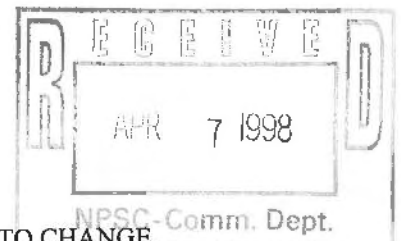

ARAPAHOE TELEPHONE COMPANY
Exchange and Network
Services Catalog

SECTION 5

Page 1

Release 1

Effective: 1-15-98

State of Nebraska

Notified: 1-9-98

22

5. EXCHANGE SERVICES

5.1 EXCHANGE AREAS

5.1.1 LIST OF EXCHANGE AREAS AND LOCAL CALLING AREAS

This section identifies exchanges and their extended area services which provides a non-optional two-way telecommunications service between main stations of separate exchanges at flat monthly rates in lieu of rates for Message Telecommunications Service. The service is provided by means of special extended area trunks between the exchanges involved.

A. Extended Area Service Increments

EAS increments apply, by EAS Group, to flat-rated service in the exchanges listed in B., following.

EAS GROUP	MONTHLY INCREMENT	
	RESIDENCE	BUSINESS
1	\$0.00	\$0.00
2	0.75	1.50

B. Exchanges by EAS Group

EAS GROUP 1:	Arapahoe	EAS GROUP 2:	Brule
	Hendley		Loomis
	Holbrook		Overton

C. Access Line Surcharge

An Access Line Surcharge will apply to each Residence or Business Access Line when such access line service in the customer's exchange is used to provide interexchange service between one foreign exchange, for which EAS with the customer's exchange is available, and another foreign exchange.

ACCESS LINE SURCHARGE: \$50.00/line/month

5.1.2 LOCAL SERVICE INCREMENTS

A. Zone Increments

The following Company exchanges offer Zoned Service outside the Base Rate in Zones A through Z:

Brule Farnam Loomis Overton

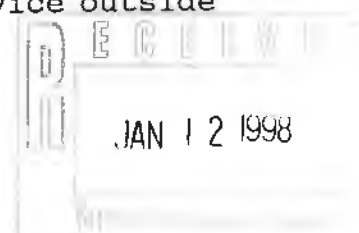

ARAPAHOE TELEPHONE COMPANY

Exchange and Network
Services Catalog

SECTION 5

Page 2

Release 1

State of Nebraska

Notified: 12-19-96

Effective: 1-2-97

5. EXCHANGE SERVICES

The following Zone Increments apply to residence and business service located outside the Base Rate Area.

ZONE	MONTHLY INCREMENT
A	\$1.25
B	3.25
C	5.75

5.1.3 MAPS

The boundaries of Base Rate Areas and Zone Rate Areas are as described or indicated on maps for each exchange which are hereby made a part of this Catalog

5.2 LOCAL EXCHANGE SERVICE

5.2.1 MEASURED SERVICE

A. Description

The following Company exchanges offer Measured Service:
Brule, Farnam, Loomis and Overton

Measured Service is a service for which rates are based upon an exchange access line and usage. Measured Service is an optional offering available to single-party customers.

There are several calling packages available under Measured Service:

BUSINESS	RESIDENCE
Budget Service	1 Hour Package
	3 Hour Package
	6 Hour Package

Each calling package may differ in the basic monthly rate as well as the usage allowance (see C. and D., following).

B. Terms and Conditions

1. Measured Service and Semipublic Metered Service are available, and are payable in advance. This service entitles the customer in any given exchange to service without other charge, to all stations bearing the designation or designations of that exchange. Customers in exchanges having Extended Area Service, as shown in 5.1.1, are also entitle to service to all stations of those exchanges shown.

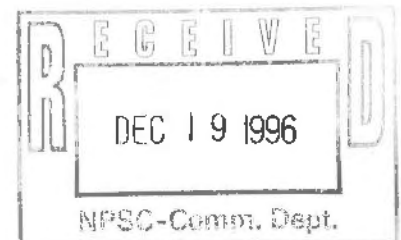

NOTICE

THE INFORMATION CONTAINED IN THIS DOCUMENT IS SUBJECT TO CHANGE.

ARAPAHOE TELEPHONE COMPANY

Exchange and Network
Services Catalog

SECTION 5

Page 3

Release 1

Effective: 1-2-97

State of Nebraska
Notified: 12-19-96

5. EXCHANGE SERVICES

2. Combinations of Measured Service and Flat Rate Service will not be allowed for business customers on the same premises, with the exception of:
 - The nonadministrative, inward terminations at a Telephone Answering Bureau.
 - A flat rate Foreign Exchange line which is switched at a location whose calling area does not include the calling area of the normal serving exchange for the Measured Service lines.
 - The selection of either Flat Rate Service or Measured Service for all administrative lines of a Radio Carrier.
3. The following services are not offered the option of subscribing to Measured Service:
 - Public and Semipublic Coin Service from noncustomer owned telephones.
4. Usage billing will be provided in bulk or summary form and not by call detail.
5. Sent paid local calls include all Dial Station-to-Station calls and those Operator Station-to-Station and Person-to-Person calls which are billed to the same telephone number from which they originated.
6. The definitions of Reversal of Charges (Collect Call) and Credit Card are defined in 5.7.3 and apply to local calls originated on Measured Service Lines.
7. The quotation of "time and charges" will not be provided for local telephone calls. This includes information concerning duration of messages and the associated charge to be billed the customer.
8. Measured Service usage charges do not apply to calls placed to the Company Business Office, Company Repair Service, Directory Assistance, 911 or "0" for emergency agencies, such as police, fire, rescue or ambulance.

C. Business

Business Measured Service customers may subscribe to Budget Service at rates and charges specified in E., following.

Rates for local usage vary, and are based upon the number of local messages, the duration (holding time) of each message, the distance between calling and called numbers, and the time of day and day of week the message originates.

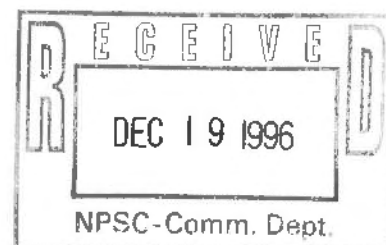

NOTICE

THE INFORMATION CONTAINED IN THIS DOCUMENT IS SUBJECT TO CHANGE.

ARAPAHOE TELEPHONE COMPANY

Exchange and Network
Services Catalog

SECTION 5

Page 4

Release 1

State of Nebraska

Notified: 12-19-96

Effective: 1-2-97

5. EXCHANGE SERVICES

1. Nonrecurring charges will not apply for conversion of an existing customer to Measured Service, for one conversion back to Flat Rate Service or from one Measured Service package to another within six months of the customer's initial conversion to Measured Service. After the six month period, applicable nonrecurring charges will apply for conversions from Measured Service to Flat Rate Service.
2. The timing of local messages begins when connection is established between the calling person and the particular person or station specified or an agreed alternate. Chargeable time ends when the connection is terminated. Chargeable time does not include time lost because of faults or defects in the service.
3. The exchange usage rates will be discounted based on holidays, time of day and day of week originated as specified in E., following.
4. Calls made and completed within the customers local exchange calling area are based on airline mileage between the customer's serving wire center and the wire center which serves the called telephone number.

D. Residence

1. Hourly Usage Package Service is a service for which rates are based upon exchange access line and usage. Hourly Usage Package Service is an optional offering available to single-party residence customers where, in the Company's judgment, central office equipment and facilities allow the offering.

There are three packages available under Hourly Usage Package Service:

RESIDENCE

- 1 Hour Package
- 3 Hour Package
- 6 Hour Package

Each calling package may differ in the basic monthly rate as well as the usage allowance.

2. The Business Classes of Service are not offered the option of subscribing to Hourly Usage Package Service.
3. Usage billing will be provided in bulk or summary form and not by call detail.
4. Rate and Charge Application
 - a. Nonrecurring charges will not apply for conversion of an existing customer to an Hourly Usage Package Service offering. Further, nonrecurring charges will not apply for conversion back to Flat Rate Service or from one of the Hourly Usage Packages to another.
 - b. The timing of local messages is the same as specified in 5.2.1(C)(2).

NOTICE

THE INFORMATION CONTAINED IN THIS DOCUMENT IS SUBJECT TO CHANGE.



ARAPAHOE TELEPHONE COMPANY

Exchange and Network
Services Catalog

SECTION 5

Page 5

Release 1

Effective: 1-2-97

State of Nebraska

Notified: 12-19-96

5. EXCHANGE SERVICES

- c. The basic monthly rates for Hourly Usage Package Service Lines are specified in E., following.
- d. The hourly allowance is applied only toward sent paid local usage charges as accumulated above.
- e. No credit is given for any unused allowance during a billing month, nor is any unused allowance accumulated and/or carried forward over billing months.

E. Rates and Charges

The nonrecurring charges apply for connecting or moving telephone service.

1. Business

a. One Party Budget Measured Service

USOC	NONRECURRING CHARGE	MONTHLY RATE			
		BASE RATE AREA	OUTSIDE BASE RATE AREA		
			ZONE A	ZONE B	ZONE C
LMB,7FB	\$33.00	\$23.25	\$24.50	\$26.50	\$29.00

b. Usage Charges

The following exchange usage rates apply in addition to the Measured Service line rates:

CALL AREA	DISTANCE IN MILES	DIAL STATION-TO-STATION	
		INITIAL MINUTE RATE	EACH ADD'L. MINUTE RATE
Zone 1	1-10	\$0.05	\$0.010
Zone 2	11-15	0.07	0.013
Zone 3	16-20	0.09	0.015
Zone 4	21-25	0.11	0.017
Zone 5	26-35	0.13	0.019

The wire centers within an exchange which are contiguous to the wire center from which a call is placed will always be included in the 0-10 mile call area.

- c. Usage charges exceeding \$20.00 per line within a monthly billing period will be discounted 30%.



NOTICE

THE INFORMATION CONTAINED IN THIS DOCUMENT IS SUBJECT TO CHANGE.

ARAPAHOE TELEPHONE COMPANY

Exchange and Network
Services Catalog

SECTION 5

Page 6

Release 5

State of Nebraska

Notified: 03.02.17

Effective: 06.01.17

5. EXCHANGE SERVICES

d. Rates Applicable on Certain Holidays

On Christmas Day, New Year's Day, Independence Day, Thanksgiving Day and Labor Day, the holiday rate applicable is the Night and Weekend rate.

e. Local Discount Time Periods

	MON	TUE	WED	THU	FRI	SAT	SUN
9:00 AM to 9:00 PM	Day Rate Period Full Rate						
9:00 PM to 9:00 AM	Night and Weekend Rate Period 50% Discount						

Discounts apply to initial minute and to additional minutes.

Discounts do not apply to operator-handled charges.

2. Residence

a. Hourly Usage Packages

- 1 Hour Package
- 3 Hour Package
- 6 Hour Package

USOC

RVE,AB3

RWV,AWV

RWC,AWJ

USOC	NONRECURRING CHARGE	MONTHLY RATE			
		BASE RATE AREA	OUTSIDE BASE RATE AREA		
			ZONE A	ZONE B	ZONE C
RVE,AB3	[1]	\$19.95	\$ 19.95	\$ 19.95	\$ 19.95 (I)
RWV,AWV	[1]	19.95	19.95	19.95	19.95 (I)
RWG,AWJ	[1]	19.95	19.95	19.95	18.00 (I)

b. Usage

- Per minute

CHARGE

\$0.02

RECEIVED

MAY 26 2017

[1] See 3.1.1.D. for nonrecurring charge application.

5.1.1 (I) - indicates an increase in a rate or charge.

Nebraska
Public Service Commission

NOTICE

THE INFORMATION CONTAINED IN THIS DOCUMENT IS SUBJECT TO CHANGE.

ARAPAHOE TELEPHONE COMPANY

Exchange and Network
Services Catalog

SECTION 5

Page 7

Release 1

State of Nebraska

Notified: 12-19-96

Effective: 1-2-97

5. EXCHANGE SERVICES

F. Measured Service and Hourly Usage Package Service Billing Options

1. Description

- a. Measured Service/Hourly Usage Package Service Billing Options will provide customers, where these services are available, several options on how local usage charges will be billed, and in which format and amount of detail the bill will be rendered.

- (1) Local Reverse Billing

This option provides for the billing of the called party (flat rate, hourly usage or measured customer) rather than the calling party for hourly or measured usage charges. Applicable conditions and rates in D., preceding, apply to Local Reverse Billing.

- (2) Local Usage Detail only with Local Reverse Billing

Local Usage Detail will provide customers detail of their local incoming measured calls under several options. Detail is available separately from the bill on either paper, magnetic tape or microfiche. This option provides the following detail: the central office prefix of the calling number, connect time, duration (holding time), date of call, and amount of each local call.

2. Terms and Conditions

- a. Local Reverse Billing is available to customers for inward calls on a per message basis. Calls must originate from telephone lines located in Company Exchanges. The customer has the option of enrolling in or withdrawing from the service at either the beginning or ending of the billing period. There will be no billing of fractional amounts.
- b. Local Usage Detail is available on a total account basis only and becomes effective on the customers billing date. The customer has the option of enrolling in or withdrawing from the service at either the beginning or ending of the billing period. There will be no billing of fractional amounts.

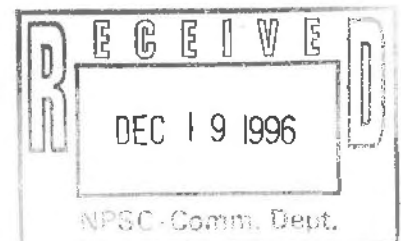

NOTICE

THE INFORMATION CONTAINED IN THIS DOCUMENT IS SUBJECT TO CHANGE.

ARAPAHOE TELEPHONE COMPANY

Exchange and Network
Services Catalog

SECTION 5

Page 8

Release 1

Effective: 1-2-97

State of Nebraska

Notified: 12-19-96

5. EXCHANGE SERVICES

3. Rates and Charges

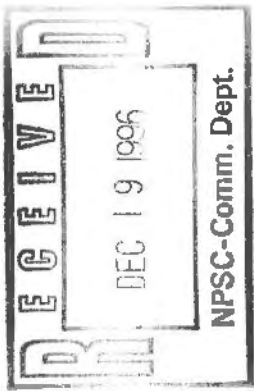

	USOC	NON- RECURRING CHARGE[1]	RATE PER LINE PER MONTH	RATE PER MESSAGE
a. Local Reverse Billing, per line or terminal arranged				
• Residence	LRB	\$ 10.00	\$ 1.50	\$ 0.01
• Business	LRB	10.00	1.50	0.01
b. Local Usage Detail, per line or terminal arranged, for inward calls				
• Residence	OMD	\$ 10.00	\$ 1.50	\$ 0.01
• Business	OMD	10.00	1.50	0.01

G. Hearing or Speech Impairment Discount

1. Description

Disabled persons who have been certified to the Company as having a hearing or speech impairment which necessitates that they communicate by a Telecommunications Device for the Deaf (TDD) (sometimes referred to as a teletypewriter or TTY device) will receive, upon written application to the Company, a discount on calls from certified residence account premises where a TDD is located.

2. Terms and Conditions

- a. The discount given will be 50% on usage.
- b. For a customer with more than one line or trunk, written application will be required for each line or trunk.
- c. The billing period for this discount will be determined by the toll billing date. The customer will receive the discount at the beginning of the next toll billing period after application approval. The customer has the option of withdrawing at either the beginning or ending of the billing period. A nonrecurring charge does not apply to establish this service.

[1] Applies in addition to applicable nonrecurring charges in E., preceding.

NOTICE

THE INFORMATION CONTAINED IN THIS DOCUMENT IS SUBJECT TO CHANGE.

ARAPAHOE TELEPHONE COMPANY

Exchange and Network
Services Catalog

SECTION 5

Page 9

Release 4

State of Nebraska
Notified: 03.02.17

Effective: 06.01.07

5. EXCHANGE SERVICES

FLAT RATE SERVICE

A. Description

Flat Rate Service is an exchange service for which a specified rate is charged regardless of the amount of usage.

B. Rates and Charges

Nonrecurring charges apply for connecting or moving telephone service. These rates do not include EAS charges found in 5.1.1.

- Residence
 - One-Party
 - Business
 - One-Party

USOC

1 FR,AFH

1FB,7FB

MONTH

USOC	NONRECURRING CHARGE	RATE AREA	BASE ZONE A	BASE RATE ZONE B	OUTSIDE AREA ZONE C
------	---------------------	-----------	-------------	------------------	---------------------

Exchanges:
Arapahoe, Hendley and Holbrook

1FR,AFH	[1]	\$19.95	\$ 0.00	\$0.00	\$0.00 (I)
	1FB,7FB	\$ 33.00	27.50	0.00	0.00 0.00

Exchanges:
Brule, Farnam, Loomis and Overton

1FR,AFH	[1]	\$ 19.95 (I)	\$ 19.95 (I)	\$ 18.15	\$ 20.65 (I)
1FB,7FB	\$ 33.00	37.55	38.80	40.80	43.30

[1] See 3.1.1.D. for nonrecurring charge application.

(I) - indicates an increase in a rate or charge.

NOTICE

THE INFORMATION CONTAINED IN THIS DOCUMENT IS SUBJECT TO CHANGE.

ARAPAHOE TELEPHONE COMPANY

Exchange and Network
Services Catalog

SECTION 5

Page 10

Release 3

State of Nebraska

Notified: 8-20-99

Effective: 1-1-2005

5. EXCHANGE SERVICES

5.2.2 LOCAL EXCHANGE OPTIONS

A. Hunting Service

1. Description

Hunting Services are optional arrangements available to customers with two or more line services at the same location, same system. Where facilities permit, lines are arranged so that incoming calls to a busy line overflow to another line in the hunting arrangement.

2. Rates and Charges

	USOC	NONRECURRING CHARGE	MONTHLY RATE
• Hunting, per line			
Residence	HTG	\$33.00	\$ 6.00
Business	HTG	33.00	6.00
• Charge to rearrange, per line			
Residence	AAV	33.00	-
Business [1,2]	AAV	33.00	-

[1] Does not apply when changing from Series Hunting to Multiline Hunting or vice versa.

[2] Applies to establish Hunting for trunks.

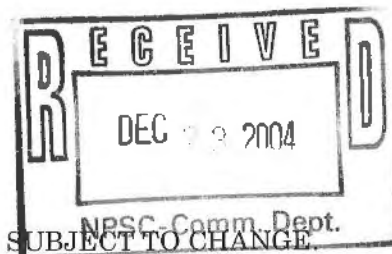

NOTICE
THE INFORMATION CONTAINED IN THIS DOCUMENT IS SUBJECT TO CHANGE.

ARAPAHOE TELEPHONE COMPANY

Exchange and Network
Services Catalog

SECTION 5

Page 11

Release 4

State of Nebraska
Notified: 06-15-2012

Effective: 07-01-2012

5. EXCHANGE SERVICES

5.2.3 TELEPHONE ASSISTANCE PROGRAMS

A. Nebraska Telephone Assistance Program (NTAP) or Lifeline Assistance

1. Description

The Nebraska Telephone Assistance Program (NTAP) or Lifeline Assistance Plan (Lifeline) assists qualified low-income applicants with reductions in their monthly local exchange service rate. The assistance applies for a single telephone line at the applicant's principal place of residence. Residents living on reservations can also qualify for the Federal position of the NTAP Lifeline program based on terms and conditions for NTAP Tribal Lifeline.

2. Eligibility Requirements

a. To be eligible for assistance, an applicant must participate in one of the following:

- Medicaid
- Food Stamps
- Supplemental Security Income (SSI)
- Federal Public Housing Assistance
- Low-Income Home Energy Assistance Program (LIHEAP)
- Temporary Assistance to Needy Family Program (TANF)
- National School Lunch Program (NSL)
- Household income at or below 135 percent of the Federal Poverty Guidelines

3. Credit

	USOC	Monthly Credit
• Nebraska Telephone Assistance Program (NTAP)	ASGSX	\$3.50
• Federal Credit	ASGF2	\$9.25
• Waiver of Federal Subscriber Line Charge (SLC)	ASGFX	\$6.50

4. Application for Assistance

An applicant shall request telephone connection assistance through completion of a form provided by the company.

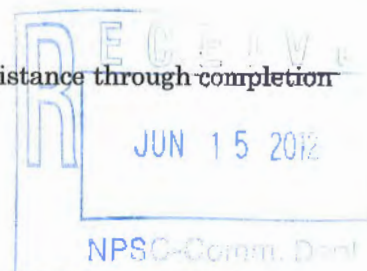

NOTICE

THE INFORMATION CONTAINED IN THIS DOCUMENT IS SUBJECT TO CHANGE.

ARAPAHOE TELEPHONE COMPANY

Exchange and Network
Services Catalog

SECTION 5

Page 12

Release 4

State of Nebraska

Notified: 06-15-2012

Effective: 07-01-2012

5. EXCHANGE SERVICES

5.2.3 TELEPHONE ASSISTANCE PROGRAMS (cont'd)

5. Deferred Payments

An applicant may defer payment of the service connection charges. Payments may be deferred up to 12 months with a payment schedule of equal payments of up to \$200.00 assessed for commencing service. Interest will not be charged on deferred payments.

6. Lifeline services included:

- Voice grade access to the public switched network
 - Local usage
 - Dual tone multifrequency signaling or its functional equivalent
 - Access to emergency services
 - Access to operator services
 - Access to interexchange service
 - Access to directory assistance
 - Toll limitation services
7. Toll limitation service, in the form of toll blocking, is offered to qualifying customers at no charge.
8. No service deposit will be collected in order to initiate Lifeline service, if the qualifying low-income customer voluntarily elects toll blocking. If the qualifying low-income customer does not voluntarily elect toll blocking, a service deposit may apply.
9. A Lifeline customer's local service will not be disconnected for non-payment of toll charges; however, a Lifeline customer's toll service may be disconnected for non-payment of toll charges.

B. Application of Telephone Assistance Programs to Concessionable Accounts

1. Description

Concession groups: These individuals will receive 100% TAP benefits less the amount of concessionable discount. For example, if the person received a 50% discount on their End User Common Line Charges, they will receive 50% of their TAP benefits.

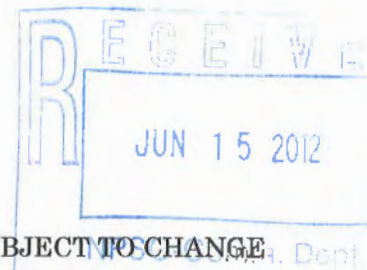

NOTICE

THE INFORMATION CONTAINED IN THIS DOCUMENT IS SUBJECT TO CHANGE

ARAPAHOE TELEPHONE COMPANY

Exchange and Network
Services Catalog

SECTION 5

Page 18

Release 4

State of Nebraska

Notified: 06-15-2012

Effective: 07-01-2012

5. EXCHANGE SERVICES

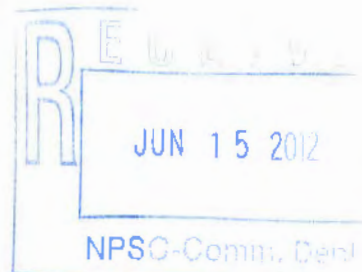

NOTICE

THE INFORMATION CONTAINED IN THIS DOCUMENT IS SUBJECT TO CHANGE.

ARAPAHOE TELEPHONE COMPANY

Exchange and Network
Services Catalog

SECTION 5

Page 14

Release 1

State of Nebraska

Notified: 12-19-96

Effective: 1-2-97

5.EXCHANGE SERVICES

Three-Way Calling

Offers the capability to add a third party to an existing call, by depressing the switchhook.

B. Terms and Conditions

1. Custom Calling products are available to individual line, residence or business customers that have their service provided from a central office equipped to provide Custom Calling. Individual Custom Calling Services will be provided where technically and economically feasible and where the Company determines sufficient demand exists to warrant the provision of the service(s).
2. Operator Verification and Interrupt will not function on lines equipped with any of the Call Forwarding features.

C. Rates and Charges

1. The following rates and charges apply for Custom Calling Services. The nonrecurring charge for business customers and/or monthly rate for business and residence customers may be waived during the term of a promotion, for existing or new customers. The term of the promotion shall be determined by the Company.

- a. Per individual line equipped with:

BUSINESS	USOC	NONRECURRING CHARGE	MONTHLY RATE
• Call Forwarding			
Busy Line (Overflow)	EVO	10.00	8.45
Don't Answer	EVD	10.00	4.00
Variable	ESM	10.00	3.00
• Call Waiting	ESX,N2W	10.00	3.00
• Speed Calling - 8	E8C	10.00	3.00
• Speed Calling - 30	E3D	10.00	3.00
• Three-Way Calling	ESC	10.00	3.00
• Four Custom Calling Services	ES7	10.00	8.00

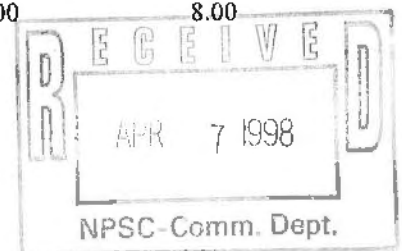

NOTICE

THE INFORMATION CONTAINED IN THIS DOCUMENT IS SUBJECT TO CHANGE.

ARAPAHOE TELEPHONE COMPANY

Exchange and Network
Services Catalog

SECTION 5

Page 15

Release 1

State of Nebraska
Notified: 12-19-96

Effective: 1-2-97

5.EXCHANGE SERVICES

RESIDENCE	USOC	RATE
• Call Forwarding		
Busy Line (Overflow)	EVO	0.25
Don't Answer	EVD	0.45
Variable	ESM	3.00
Discounted	NLRXZ	1.50
• Call Waiting	ESX,N2W	3.00
• Speed Calling - 8	E8C	3.00
Discounted	NLRXW	1.00
• Speed Calling - 30	E3D	3.00
• Three-Way Calling	ESC	3.00
Discounted	NLRXR	1.75
• Four Custom Calling Services	ES7	8.00

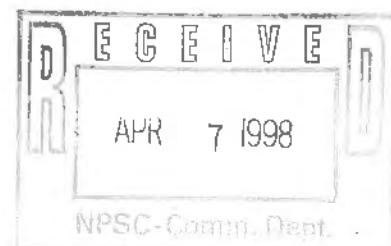

NOTICE
THE INFORMATION CONTAINED IN THIS DOCUMENT IS SUBJECT TO CHANGE.

ARAPAHOE TELEPHONE COMPANY

Exchange and Network
Services Catalog

SECTION 5

Page 16

Release 1

State of Nebraska
Notified: 12-19-96

Effective: 1-2-97

5.EXCHANGE SERVICES

5.4 PUBLIC COMMUNICATION SERVICE - COIN AND COINLESS

5.4.1 PUBLIC TELEPHONE SERVICE

A. Description

Public Service is a customer service, with or without coin collection equipment, designed for locations where there is general public use

B. Terms and Conditions

1. A public telephone is provided at the Company's initiative, or at its option, at a location accessible to the public, where warranted by public necessity or by the revenue to be received, and where the occupant of the premises agrees to permit the installation of such service in accordance with terms to be agreed upon between the occupant and the Company. Coin boxes are provided on non-attended stations.
2. The primary purpose of Public Telephone Service is to provide service for the general public and the use of the service by occupants of the premises where it is located is only incidental to the principal purpose.
3. "Local Messages" are messages to any line that subscribers may call from any public line without payment of toll charges.
4. The "Payphone Set Use Fee" is an incremental charge applied to all intraLATA MTS calls originating at a Company payphone. This charge is in addition to MTS rates and operator assistance charges. The exceptions are as follows:
 - 800/800-type service (including 800 Carrier Access)
 - Directory Assistance
 - 911
 - 0- emergency
 - 0- non-revenue calls to an operator
 - Local Busy Line Verify/Local Busy Line Interrupt
 - 950, 10XXX
5. Public telephone signs are displayed at the option of the Company.
6. Where requested by the site provider/premises owner and at the discretion of the Company, the local message rate may be priced at \$0.25. The rate will only apply on direct dialed cash calls and in closed campus environments that are not accessible to the general public, which meet Company specific criteria.
7. The charge for a long distance message paid for by coin deposit in a Public Coin telephone is the sum, rounded to the nearest \$0.05, of the appropriate initial period rate and additional period charges.

NOTICE

THE INFORMATION CONTAINED IN THIS DOCUMENT IS SUBJECT TO CHANGE.

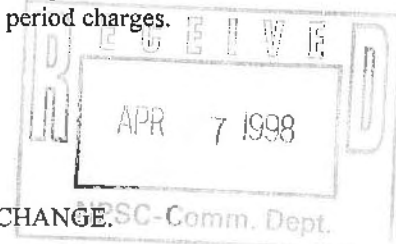

ARAPAHOE TELEPHONE COMPANY

Exchange and Network
Services Catalog

SECTION 5

Page 17

Release 1

State of Nebraska

Notified: 12-19-96

Effective: 1-2-97

5. EXCHANGE SERVICES

8. The rates for all local messages from Public lines that require operator assistance include the appropriate local operator assistance charge for the type of call in addition to the local message rate specified in C., following.

C. Message Charges

	CHARGE
• Local message, each[1]	\$ 0.35
• Payphone Set Use Fee, per call	0.35

[1] Operator-handled charges may also apply.

5.4.2 SEMIPUBLIC SERVICES

A. Semipublic and Shared Payphone Service

1. Description

Semipublic and Shared Payphone Services are services with coin collecting equipment, designed for locations where there is a combination of customer and public use.

2. Definition

Local Messages

Messages to any line that customers may call from any public or semipublic or shared payphone line without payment of toll charges.

Payphone Set Use Fee

An incremental charge applied to all intraLATA MTS calls originating at a Company payphone. This charge is in addition to MTS rates and operator assistance charges. The exceptions are as follows:

- 800/800-type service (including 800 Carrier Access)
- Directory Assistance
- 911
- 0- emergency
- 0- non-revenue calls to an operator
- Local Busy Line Verify/Local Busy Line Interrupt
- 950, 10XXX



NOTICE

THE INFORMATION CONTAINED IN THIS DOCUMENT IS SUBJECT TO CHANGE.

ARAPAHOE TELEPHONE COMPANY

Exchange and Network
Services Catalog

SECTION 5

Page 18

Release 1

State of Nebraska
Notified: 12-19-96

Effective: 1-2-97

5. EXCHANGE SERVICES

3. Terms and Conditions

Semipublic and Shared Payphone Service will be furnished only where, in addition to customer use, there is a substantial demand for service by patrons, transients, guests, members, employees or other occupants of the premises. It will not be furnished at locations where service is desired solely for the use of the customer.

- a. Semipublic and Shared Payphone Service are furnished at the option of the Company where the nature of usage indicates that it is suited to meet the requirements at the location. Semipublic and Shared Payphone Service must be placed in a location accessible to those users for whom it is intended.
- b. Public telephone signs are displayed at the option of the Company.
- c. Semipublic and Shared Payphone Service may be equipped with coin collecting devices and are connected to individual lines.
- d. Joint User Service is furnished in connection with these services at the regular rate for business Joint User Service.
- e. Service is furnished the customer, if desired, and directory listings are provided under the conditions governing the furnishing of listings for business main line customers, except that residence listings in connection with service furnished boarding or rooming houses, or at other locations where the party desiring the additional listing resides, are furnished under the conditions governing the furnishing of listings for residence main line customers.
- f. Where service is furnished outside the base rate area, extra exchange line mileage charges are applicable in the same manner as for other town main line services. Excess construction charges, if any, will be applied in the same manner as for other town main line services.
- g. Semipublic and Shared Payphone Service is offered subject to the availability of facilities for furnishing this type of service.
- h. Connections of Customer-Provided Data Terminal Equipment
 - (1) Direct Electrical Connection
 - Customer-provided data terminal equipment may be connected to Semipublic and Shared Payphone Service subject to the following conditions: Such connections shall be in accordance with the following:

Nonregistered, customer-provided data equipment may be connected through customer-provided registered or grandfathered protective circuitry.

Customer-provided registered or grandfathered data equipment may be directly connected.

NOTICE

THE INFORMATION CONTAINED IN THIS DOCUMENT IS SUBJECT TO CHANGE.

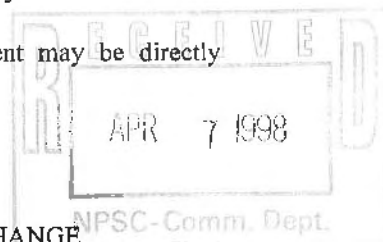

ARAPAHOE TELEPHONE COMPANY

Exchange and Network
Services Catalog

SECTION 5

Page 19

Release 1

State of Nebraska
Notified: 12-19-96

Effective: 1-2-97

5.EXCHANGE SERVICES

Customer-provided registered or grandfathered data equipment may be connected to a Semipublic or Shared Payphone additional telephone set location.

To prevent the interruption or disconnection of a call, or interference with network control signaling, it is necessary that the signal applied by the customer-provided equipment to the Company interface located on the customer's premises at no time have energy solely in the 2450 to 2750 Hertz band. If signal power is in the 2450 to 2750 Hertz band, it must not exceed the power present at the same time in the 800 to 2450 Hertz band.

- Such connection is permitted only for incoming calling. These calls may be answered either manually or automatically. When calls are answered automatically, the customer-provided terminal equipment must have an "on-off" switch or sufficient control logic to prevent the data set or Data Access Arrangement from being commanded to answer all incoming calls. If not so equipped, a cutoff key must be provided by the customer to remove the data terminal location from the line during regular business hours.
- Such connection is permitted only during off-hours. These are the period of time when outgoing calls by the public are not anticipated. Customers subscribing to Semipublic and Shared Payphone Services must sign an agreement to this effect.
- The customer-provided equipment must be capable of either retransmitting information on all automatically answered calls or must be capable of performing the appropriate series of identification functions with the calling data station before data transmission begins.
- A visual signal provided by the customer needs to be used to indicate when the data terminal is in use so as to protect users of the Semipublic or Shared Payphone Service except in situations where the public has no access to the telephone during off-hours. Where the visual signal is provided, it shall be located near the telephone so as to be capable of being seen by potential users of the telephone and a sign indicating the meaning of the visual signal shall be posted at the signal location.

(2) Acoustic or Inductive Connections

- Customer-provided data terminal equipment may be acoustically or inductively connected to Semipublic and Shared Payphone Services, subject to the conditions both in this section and in Sections 2.
- Such connection is permitted as specified in (1), preceding.

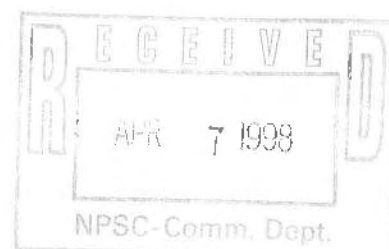

NOTICE

THE INFORMATION CONTAINED IN THIS DOCUMENT IS SUBJECT TO CHANGE.

ARAPAHOE TELEPHONE COMPANY

Exchange and Network
Services Catalog

SECTION 5

Page 20

Release 1

State of Nebraska
Notified: 12-19-96

Effective: 1-2-97

5. EXCHANGE SERVICES

4. Rates and Charges

a. Access Lines

		MONTHLY RATE			
		BASE RATE AREA	OUTSIDE BASE RATE AREA		
USOC	NONRECURRING CHARGE		ZONE A	ZONE B	ZONE C
Semipublic		\$37.55	\$38.80	\$40.80	\$43.30
Shared Payphone		39.00	40.25	42.25	44.75

b. Change Charge

Where the Semipublic or Shared Payphone instrument or enclosure must be moved and/or changed, the following nonrecurring charge applies:

	USOC	NONRECURRING CHARGE
Each instrument moved or changed	MVM	\$ 35.00

c. Message Charges

See 5.4.1 for applicable message charge and associated terms and conditions.

d. Payphone Set Use Fee

Payphone Set Use Fee, as specified in 5.4.1, applies.

e. Enclosures

Enclosures may be furnished by the Company for use by a customer in connection with Semipublic or Shared Payphone Service. Time and material charges apply in addition to nonrecurring charges.

	NON- RECURRING CHARGE	MONTHLY RATE SEMI- PUBLIC	SHARED PAYPHONE
Shelf	\$ 33.00	\$ 2.50	\$ 2.70
Small Walk-Up	33.00	4.95	7.35
Large Walk-Up	33.00	9.90	11.80

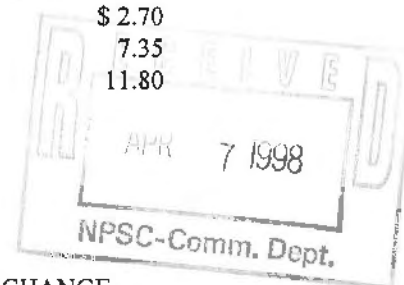

NOTICE

THE INFORMATION CONTAINED IN THIS DOCUMENT IS SUBJECT TO CHANGE.

ARAPAHOE TELEPHONE COMPANY

Exchange and Network
Services Catalog

SECTION 5

Page 21

Release 1

State of Nebraska
Notified: 12-19-96

Effective: 1-2-97

5. EXCHANGE SERVICES

5.4.3 COINLESS PUBLIC TELEPHONE SERVICE

A. Description

Coinless Public Telephone Service is furnished at the Company's initiative or at its option when warranted for the purpose of satisfying the demand for optional billing of outgoing messages. Coinless Public Telephone Service offers the following options for the billing of outgoing messages: charging to a third number; a Company credit card; or collect. In certain locations, calls may be billed on a collect basis only.

B. Terms and Conditions

1. Coinless Public Telephone Service may be provided on the premises of city, county, state and federal correctional institutions where potential usage by inmates participating in authorized telephoning programs warrants establishing the service. Such telephones will be provided for the purpose of originating long distance collect messages to numbers in the United States, Canada and Mexico or originating local collect messages. All other traffic, including calls to Company numbers, INWATS numbers and public emergency services numbers such as 911, will be blocked.

The Company reserves the right to deny or terminate such service if unsatisfactory revenues or collection experiences are indicated.

2. Coinless Public Telephones are not equipped with coin collecting devices or receptacles. They may be furnished with booths, shelves and directories at the discretion of the Company.
3. In those areas where security arrangements restrict access to the central Coinless Public Telephone location, the Company may elect to provide jacks through which the telephone may be connected to the network at appropriate times.

C. Message Charges

See 5.4.1 for applicable message charges, terms and conditions.

5.4.4 PUBLIC ACCESS LINE (PAL) SERVICE

A. Description

1. Public Access Line (PAL) Service will apply for use with customer-provided coin or noncoin operated telephones at locations accessible to the public, e.g., stores, business places, including boarding or rooming houses and school or college buildings, where desired by the owner of the premises.
2. PAL Service is available on a metered or measured basis for coin operated telephones in those central offices which have been equipped to provide such service and in all central offices on a flat rate basis for coin and noncoin operated telephones.
3. Joint User Service may be furnished in connection with PAL Service.

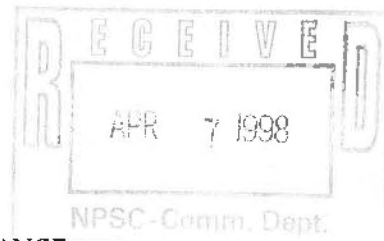

NOTICE

THE INFORMATION CONTAINED IN THIS DOCUMENT IS SUBJECT TO CHANGE.

ARAPAHOE TELEPHONE COMPANY

Exchange and Network
Services Catalog

SECTION 5

Page 22

Release 1

State of Nebraska
Notified: 12-19-96

Effective: 1-2-97

5. EXCHANGE SERVICES

4. Directory listings may be provided under the conditions governing the furnishing of listings specified in 5.5.1 for business main line customers. However, listings (not indicating a business or profession) provided in connection with PAL Service furnished at boarding or rooming houses or at other locations where the party desiring the additional listings resides, are furnished under the conditions covering the furnishing of listings specified in 5.5.1, in connection with residence main line service.

B. Definitions

Message Rate Service

Message Rate Service is a service for which usage charges apply for each completed outgoing local call.

C. Terms and Conditions

1. The customer shall be responsible for the installation, operation and maintenance of any customer-provided coin operated telephones used in connection with this service.
2. The customer shall be responsible for the payment of a Trouble Isolation Charge for visits by a Company employee to the customer's premises when a service difficulty or trouble report results from the use of customer-provided coin or noncoin-operated telephones and facilities.
3. The customer shall be responsible for payment of charges for all messages originating from or accepted at this type of service.
4. Customer-provided coin operated telephones must be registered in compliance with Part 68 of the Federal Communication's Commission (FCC's) Registration Program or connected behind FCC registered coupler.
5. Such customer-provided coin or noncoin operated telephones must have the following operational characteristics:
 - a. Must be able to access the Company operator (0- level) at no charge and without using a coin.
 - b. Must be able to access 911 Emergency Service, where available, at no charge, without using a coin, and, when such instrument can only access 911 Emergency Service by use of a dialing sequence other than 911, must prominently display on such instrument, the appropriate dialing sequence to access 911 Emergency Service, where available.
 - c. Must be able to access all interexchange carriers unless the customer is an interexchange carrier in which case access may be limited to that carrier.
 - d. Must comply with all applicable federal, state and local laws and conditions concerning the use of these telephones by disabled persons and the hearing impaired.
 - e. Must allow the completion of both local and long distance calls from the zero 0- level and 0+ direct dialed level.

NOTICE

THE INFORMATION CONTAINED IN THIS DOCUMENT IS SUBJECT TO CHANGE.

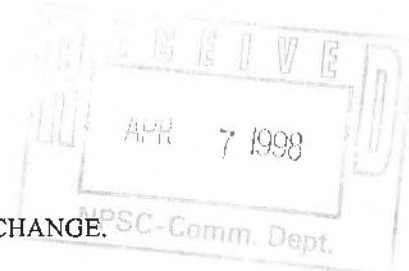

ARAPAHOE TELEPHONE COMPANY

Exchange and Network
Services Catalog

SECTION 5

Page 23

Release 1

State of Nebraska
Notified: 12-19-96

Effective: 1-2-97

5. EXCHANGE SERVICES

6. The customer shall prominently display on each customer-provided coin or noncoin operated telephone used in connection with this service the name of the owner of the instrument, the procedure for reporting service difficulties and obtaining customer refunds, and a range of percentages by which the cost to the customer of long distance calls is increased to the user of the equipment.
7. Where any customer-provided coin or noncoin operated telephone is in violation of this Catalog, the Company will promptly notify the customer of the violation and will take immediate action, including the disconnection of service, as is necessary for the protection of the telecommunications network and the Company employees.
8. The customer shall discontinue use of the customer-provided coin or noncoin operated telephone or correct the violation and notify the Company in writing within five days after receipt of the notice that the violation has been corrected.
9. Failure of the customer to discontinue such use or to correct the violation will result in the suspension of the customer's service until such time as the customer complies with the provisions of this Catalog.
10. In order to provide adequate service only one coin operated instrument per PAL is allowed. The line cannot be switched, multiplexed or concentrated. Telephones for answering purposes may be furnished for use by the customer, but cannot be equipped with coin collecting devices.

D. Rates and Charges

1. A "local message" from PAL Service served by a given exchange is a completed local call, originating at such service and terminating at any service which may be called, without toll charge, from all other service served by the exchange concerned.
2. PAL customers may assess applicable Directory Assistance charges to users of their coin. or noncoin operated telephones.

NOTICE

THE INFORMATION CONTAINED IN THIS DOCUMENT IS SUBJECT TO CHANGE. SC-Comm. Dept.

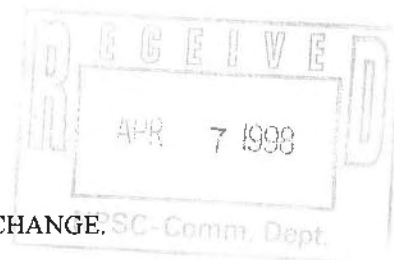

ARAPAHOE TELEPHONE COMPANY

Exchange and Network
Services Catalog

SECTION 5

Page 24

Release 1

State of Nebraska
Notified: 12-19-96

Effective: 1-2-97

5. EXCHANGE SERVICES

3. PAL Service is provided at the following rates and charges:

	USOC
Flat PAL Service[1]	
- Two-way service	1KY
- Outgoing only service	1GY
Message PAL Service[2]	
- Two-way service	17Q
- Outgoing only service	16Q
Measured PAL Service[3]	
- Two-way service	12G
- Outgoing only service	11G

		MONTHLY RATE			
		BASE RATE AREA	OUTSIDE BASE RATE AREA		
USOC	NONRECURRING CHARGE		ZONE A	ZONE B	ZONE C
1KY,1GY	\$80.00	\$41.50	\$42.75	\$44.75	\$47.25
17Q,16Q	80.00	23.25	24.50	26.50	29.00
12G,11G	80.00	[3]	[3]	[3]	[3]

EAS rates, specified in 5.1.1, apply.

Message usage charges also apply

Use Budget Service rates and charges plus measured usage rates, specified in 5.2.1, preceding.

	CHARGE
Message Usage Charge, per message	\$0.06

E. Vendor Billing Service

1. Description

Vendor Billing Service is an arrangement whereby the Company provides billing and collection services for Public Access Line customers. The offering includes billing a surcharge on the end user's bill when placing a non-sent paid intraLATA call utilizing the Company's long distance Message Telecommunications Service (MTS) from the PAL coin/coinless line, collecting the surcharge amount as well as remittance of funds due to the PAL customer.

Remittance of funds will be provided to the PAL customer after applicable Company charges are deducted.

NOTICE

THE INFORMATION CONTAINED IN THIS DOCUMENT IS SUBJECT TO CHANGE.

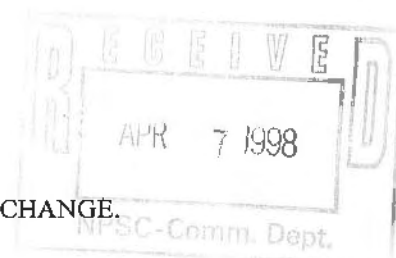

ARAPAHOE TELEPHONE COMPANY

Exchange and Network
Services Catalog

SECTION 5

Page 25

Release 1

State of Nebraska
Notified: 12-19-96

Effective: 1-2-97

5. EXCHANGE SERVICES

2. Terms and Conditions

- a. The PAL customer will determine the price of the surcharge to the end user.
- b. The PAL customer must subscribe to the appropriate Toll Screening Service, specified in 10.2.1, which is compatible with Vendor Billing Service for each line used in the provision of PAL Service.
- c. The Company will furnish and maintain the facilities required for proper surcharge processing.
- d. The Company will provide billing, collection, and inquiry for the surcharge.
- e. The surcharge will appear on the Local Exchange Carrier page of the end user's monthly bill for all non-sent paid intraLATA calls originating on the PAL line and using the Company's MTS.
- f. The PAL customer will be required to sign a contract outlining the terms and conditions under which Vendor Billing Service will be provided.

3. Charges

The following charges are in addition to the rates and charges for a PAL line or other services associated with the line.

	CHARGE
Per surcharge billed to an end user	\$ 0.10

NOTICE

THE INFORMATION CONTAINED IN THIS DOCUMENT IS SUBJECT TO CHANGE.

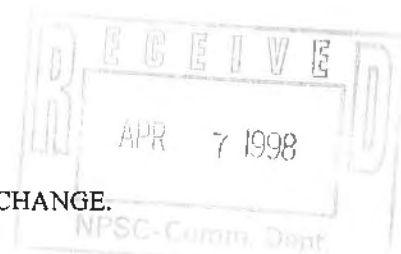

ARAPAHOE TELEPHONE COMPANY

Exchange and Network
Services Catalog

SECTION 5

Page 26

Release 1

State of Nebraska
Notified: 12-19-96

Effective: 1-2-97

5.EXCHANGE SERVICES

5.5 DIRECTORY SERVICES

5.5.1 DIRECTORY LISTINGS

A. Description

1. The alphabetical telephone directory is an alphabetical list, with telephone numbers and addresses of customers, joint users and others who are entitled to use the customer's telephone service under the terms and conditions governing such use. The basic purpose of the alphabetical directory is to provide a convenient means for obtaining telephone numbers for the completion of calls. To insure that this fundamental purpose is fulfilled, the Company reserves the right to determine the propriety of any listing to be included in the directory.
2. The directory for each exchange is published at intervals determined by the Company. In some directories the customers of two or more exchanges may be listed in the same directory, either in separate sections or in one list as determined by the Company. A directory may list the customers of certain but not all of the service areas of a multiservice area exchange.

B. Terms and Conditions

1. A customer's listing may be omitted from the directory but otherwise posted the information records and will be given out on request. This is referred to as "nonlisted" service.
2. A customers listing may be omitted from the directory but will be posted on the information records without a telephone number. This is referred to as "nonpublished" service.
3. The following listing exceptions are furnished without monthly charges either as Nonlisted or Nonpublished Directory Service.

Other listed telephone service in the same name at the same address

Other listed telephone service in the same name in the same exchange

SRC and FXS where the customer has local exchange service

Temporary service (construction sites, elections, special events, etc.)

Service involving data terminals where there is no voice use contemplated

4. When the no charge exceptions listed above are Nonpublished Directory Service, B.2., preceding, does not apply, and the name as well as the telephone number are omitted from Directory Assistance Records.
5. Listings shall be the names of individuals, businesses, clubs, associations, corporations or partnerships of subscribers or authorized users of exchange telephone service.

NOTICE

THE INFORMATION CONTAINED IN THIS DOCUMENT IS SUBJECT TO CHANGE.

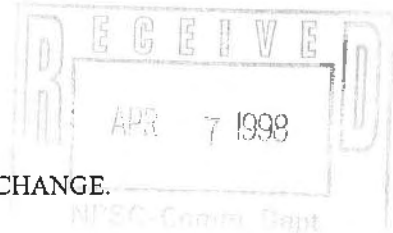

ARAPAHOE TELEPHONE COMPANY

Exchange and Network
Services Catalog

SECTION 5

Page 27

Release 1

State of Nebraska
Notified: 12-19-96

Effective: 1-2-97

5. EXCHANGE SERVICES

6. As an aid in identifying business customers, certain business or professional designations are furnished in connection with listings for business service. If, in the judgment of the Company, it is necessary in order to properly identify a listing, descriptive titles or designations may also be furnished in connection with listings of residence service. Business designations are not furnished in connection with listings of residence service.
7. Normally all listings will be spelled in full and common abbreviations will be used only with customer acceptance. Where more than one line is required to properly list a person or firm, no additional charge is made.
8. Limitations concerning content of primary and additional listings.
 - a. Any form of listing which does not facilitate directory service or is otherwise objectionable or unnecessary for purposes of identification is not permitted.
 - b. The listing of a service, commodity or trade name will not be permitted except when the name of the service, commodity or trade name is the name or an integral part of the name under which the listed party is doing business.
 - c. Listings that include advertising, such as words describing a product or including the price of a product or service, are not permitted.
 - d. Names designed to alphabetize a customer's listing ahead of or near competitor's listings are not permitted.
 - e. Listings are not permitted which are offensive to good taste.
 - f. Listings which are a subterfuge for illegal goods or services are prohibited.
 - g. The Company may require evidence of consent to the use of any name other than that of the customer.
 - h. Evidence may be required in the form of canceled checks, letterheads, invoices, tax receipts, or other documents which, in the opinion of the Company, substantiates that a name is in fact the name under which business is regularly conducted.
9. The Company's liability arising from errors in or omissions of directory listings will be limited to one-half the charges for the service affected for the period between the issuance of the directory in which the error or omission occurred and the publication of a new directory containing the proper listing.

NOTICE

THE INFORMATION CONTAINED IN THIS DOCUMENT IS SUBJECT TO CHANGE.



ARAPAHOE TELEPHONE COMPANY

Exchange and Network
Services Catalog

SECTION 5

Page 28

Release 1

State of Nebraska
Notified: 12-19-96

Effective: 1-2-97

5. EXCHANGE SERVICES

10. Types of listings

a. Primary listings

- (1) A primary listing is provided as a part of, and is included in the rate for, exchange telephone service. It is furnished in the directory of the serving exchange.
- (2) A primary listing is normally the name and address of:
 - The person or firm contracting for exchange telephone service
 - A joint user
 - A party for whom the exchange telephone service was contracted for by another party
 - The name under which a firm regularly conducts business
 - Two individuals residing at the same address, with the same or different surname and given names. Each given name, for purposes of this catalog, is defined as any combination, not to exceed two, of the following:
 - First name
 - Middle name
 - Initial
 - Nickname
 - Maiden name
 - An additional listing reversing the order of the individuals' given names may be obtained at the rates for regular additional listings as specified in rates following. The restriction of no more than two given names applies only to listings involving two individuals' names.
- (3) The primary listing, provided with a customer's second residence exchange service line, may be the names or names and address of members of a customer's family residing in the customer's household. Such primary listings with more than one name must be indented under another primary listing.
- (4) When two or more lines serve a customer in a group arranged for a "hunting" operation, each group of lines is considered one telephone number and is entitled to only one primary listing.
- (5) Except as outlined above, a primary listing is provided with each main line associated with Business, Residence, Semipublic, Rural, Automatic Call Distribution, and with each Joint User. One primary listing is provided for each customer to Group Use Exchange Service.
- (6) If a customer or joint user has both business and residence service, the primary residence listing may be indented under the business listing without repeating the name.

b. Additional Listings

NOTICE

THE INFORMATION CONTAINED IN THIS DOCUMENT IS SUBJECT TO CHANGE.



ARAPAHOE TELEPHONE COMPANY

Exchange and Network
Services Catalog

SECTION 5

Page 29

Release 1

State of Nebraska
Notified: 12-19-96

Effective: 1-2-97

5. EXCHANGE SERVICES

- (1) A listing arrangement of not more than two individuals with the same or different surname(s), sharing the same service, and residing at the same address, may also be provided as additional listings.
- (2) Additional listings are those listings furnished in addition to the primary listing at the rates shown herein. There are five kinds of additional listings - regular, alternate, foreign, temporary and cross references.
- (3) Additional listings are available for customers of those Miscellaneous Common Carriers with which arrangements have been made for the interchange of telephone traffic subject to the concurrence of the Carrier. For such listings the telephone number of the connecting circuit shall be listed.
- (4) Where a customer is served by two or more lines in a group arranged for a "hunting" operation, additional listings may be provided on any of the lines in the group.
- (5) Charges for additional listings date from the day the related service order is completed.
 - Additional listing service is furnished only by directory periods established by the Company. Subject to the conditions hereinafter set forth, the charges for such service may be terminated prior to the expiration of an established period.
 - Except as hereinafter provided, the charge for an additional listing which has been posted on the information records, but which has not appeared in the directory may be terminated at any time upon payment of charges due to time of termination of the listing, subject to a minimum of one month's charges.
 - Additional listings appearing in the current directory may be terminated at other than directory periods only when, due to termination of the access line service, removal of the listed party from the location of the access line service, installation of separate access line service for the listed party, or other causes, it is evident that the listing has no further value. Such termination is subject, however, to payment of a minimum of charges except as hereinafter provided.
- (6) Additional listings may be provided without charge where in the opinion of the Company they are essential to the convenient use of the directory. These are often referred to as cross reference listings.
- (7) Business Additional Listings
 - If qualified under conditions governing use of the service, additional listings may be the name of the customer or joint user; the names of members of the firm, names of officers of the corporation, club, association, partnership or business, the names of employees or representatives of the customer or joint user, the names of firms, persons, corporations, associations, or institutions which the customer or joint user owns, controls or represents.

NOTICE

THE INFORMATION CONTAINED IN THIS DOCUMENT IS SUBJECT TO CHANGE.

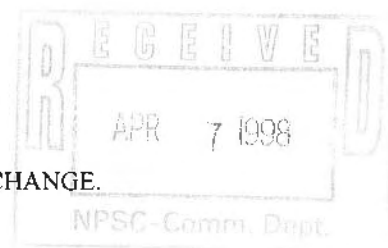

ARAPAHOE TELEPHONE COMPANY

Exchange and Network
Services Catalog

SECTION 5

Page 30

Release 1

State of Nebraska
Notified: 12-19-96

Effective: 1-2-97

5. EXCHANGE SERVICES

- Representation is defined as the relationship in which one acts as an agent for another. It does not include cases where one sells commodities or performs other services, but in so doing acts for themselves and not as the agent for another.

(8) Residence Additional Listings

- If qualified under conditions concerning use of the service, they may be the name of the customer, the names of members of the family, and others residing in the household; names of permanent guests or tenants who maintain their residence in a family hotel or apartment house, dormitory, transient hotel or club, where the service of such guests or tenants is provided through the private branch exchange of the hotel or apartment house, dormitory, transient hotel or club; the names of permanent guests who maintain their residence in a boarding or rooming house where service is provided by means of semipublic telephone service.
- A residence customer who has regular additional business listings, may have the residence service indented under such business listing.
- Where business service is located in a residence, it is permissible to provide residence additional listings in connection with such business service.

(9) Alternate Listings

Alternate listings refer a directory user to another telephone number during certain periods of time or where a called telephone is not answered.

(10) Foreign Listings

A foreign listing is a listing in an alphabetical directory of an exchange other than the one in which the primary listing is furnished.

NOTICE

THE INFORMATION CONTAINED IN THIS DOCUMENT IS SUBJECT TO CHANGE.



ARAPAHOE TELEPHONE COMPANY

Exchange and Network
Services Catalog

SECTION 5

Page 31

Release 1

State of Nebraska
Notified: 12-19-96

Effective: 1-2-97

5.EXCHANGE SERVICES

(11) Temporary Listings

A temporary listing is a listing furnished to persons leasing or subleasing the premises of a customer during his temporary absence who have arranged to use the customer's service during that time.

As provided for under 2.2.1, persons leasing or sub-leasing premises of residence customers for periods of less than one year, during temporary absences of the customers, are permitted to use the service furnished the customers upon request of the latter to render service to their tenants without change in the responsibility for all billing and contractual arrangements.

(12) Cross Reference Listings

A cross-reference listing is a listing of the name by which the customer is commonly known to the public and includes a reference to the customer's other listed name. Cross-reference listings may include the customer's telephone number. These listings may be provided without charge where, if the opinion of the Company, they are essential to the convenient use of the directory or where their use will facilitate the handling of telephone calls.

At the discretion of the Company, cross-reference or duplicate listings may be furnished without charge, as a public service, where it appears such cross-referencing will facilitate accurate and rapid completion of calls and lessening of the load of information board calls, based on public habit and custom.

c. Nonpublished and Nonlisted Information Disclosure

Nonpublished and nonlisted telephone numbers including the name and address of the customer may be displayed on a call-by-call basis at Public Service Answering Points (PSAP) that are equipped with Enhanced 911 (E911) Universal Emergency Number Service.

Nonpublished and nonlisted telephone numbers may be delivered to customers of Caller identification Service for display to those customers on a call-by-call basis, to customers who subscribe to Company offerings which require the information to provide service and/or bill their clients, to telephone customers who are billed for calls placed to or from such telephone numbers, and to entities which collect for the billed services.

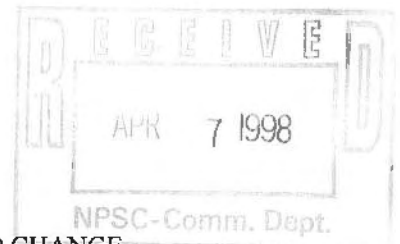

NOTICE

THE INFORMATION CONTAINED IN THIS DOCUMENT IS SUBJECT TO CHANGE.

ARAPAHOE TELEPHONE COMPANY

Exchange and Network
Services Catalog

SECTION 5

Page 32

Release 1

State of Nebraska
Notified: 12-19-96

Effective: 1-2-97

5. EXCHANGE SERVICES

C. Rates and Charges

1. The appropriate nonrecurring charge applies for business customers to each:

Change in primary listing other than when the customer moves to a new address;

Additional listing established or changed;

Nonpublished or nonlisted service established or changed;

Business service, to transfer the service of a customer to an applicant with a change in the primary listing when the same business is continued and there is no lapse in service;

Change from one nonpublished service to a nonlisted service or a nonlisted service to a nonpublished service

2. The nonrecurring charge for business customers will not apply to:

Change from nonpublished or nonlisted to listed service;

Transfer business service of a customer to an applicant without a change in the primary listing when the same business is continued and there is no lapse in service.

3. Listing Rates and Charges

- a. Nonlisted and nonpublished service rates and charges do not apply:

- (1) To Special Reverse Charge Toll Service.

- (2) To Foreign Exchange Service where the customer is also furnished Local Exchange Service.

- (3) To any service furnished to the same customer which is in addition to a published service, providing the additional service is in the same name and is furnished either in the same exchange or in an exchange in which directory listings are intersorted with those of the exchange in which the published listing appears.

- (4) To a customer living in a hotel, hospital, retirement complex, apartment house, boarding house, or club if the customer is listed under the telephone number of Semipublic Service furnished to the hotel, hospital, retirement complex, apartment house, boarding house or club.

- (5) To Inward Wide Area Telecommunications Service.

- (6) To nonlisted service in excess of one per customer where the customer has additional service of the same type (nonlisted service) in the same name and furnished either in the same

NOTICE

THE INFORMATION CONTAINED IN THIS DOCUMENT IS SUBJECT TO CHANGE.

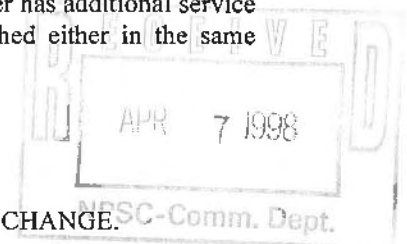

ARAPAHOE TELEPHONE COMPANY

Exchange and Network
Services Catalog

SECTION 5

Page 33

Release 1

State of Nebraska
Notified: 12-19-96

Effective: 1-2-97

5. EXCHANGE SERVICES

exchange or in a different exchange, providing there is an intersort arrangement for directory listings of both exchanges.

	USOC	NONRECURRING CHARGE	MONTHLY RATE
Additional, Alternate, Temporary, Cross Reference, each			
Business	CLT,FNA,NSH	\$10.00	\$5.00
Residence	RLT	-	1.50
Discounted[1]	NLYXA	-	0.75
Foreign, each			
Business	FAL	10.00	5.00
Residence	FAL	-	1.50
Discounted[1]	NLYXB	-	0.75
Informational, each			
Business	XLL	10.00	5.00
Residence	XLL	-	1.50
Discounted[1]	NLYXC	-	0.75
Nonlisted, each			
Business	NLT	10.00	2.50
Residence	NLT	-	2.00
Nonpublished, each			
Business	NPU	10.00	3.00
Residence	NPU	-	3.00
Listing Change, each			
Business	1W1	10.00	-
Residence	1W1	10.00	-

[1] See Custom Solutions.

5.5.2 CUSTOM NUMBER SERVICE

A. Description

This service is applicable for telephone number assignment when the customer requests a specific telephone number other than those offered by the Company. If the telephone number requested is available, the Company may assign the number to the customer.

NOTICE

THE INFORMATION CONTAINED IN THIS DOCUMENT IS SUBJECT TO CHANGE.

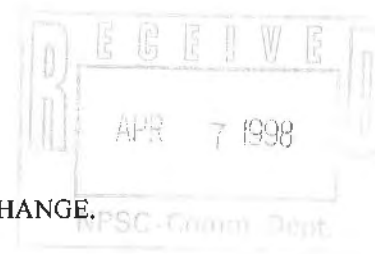

ARAPAHOE TELEPHONE COMPANY

Exchange and Network
Services Catalog

SECTION 5

Page 34

Release 1

State of Nebraska
Notified: 12-19-96

Effective: 1-2-97

5. EXCHANGE SERVICES

B. Terms and Conditions

1. Custom Number charges are not applicable to the following services:

800 Service

976/960 Service

Number Blocks

2. The Company will offer up to five numbers for customers to choose from at no charge. If a customer requests further or more specific number choices, there will be a charge based on the customer's needs as specified hereafter. Custom Number nonrecurring charges will not apply when the customer requests assignment of the same number within one year of termination.
3. The Company reserves and retains the right:
 - a. To discontinue a charge or reassign telephone numbers in any exchange area whenever it deems it necessary or appropriate in the conduct of its business, or in accordance with the rules and regulations of the Company. If this should occur within a one year period following assignment, the Custom Number nonrecurring charges will be refunded to the customer.
 - b. To reject any request for specific numbers for any reason, including, but not limited to, numbers that may, in the Company's opinion, be offensive to good taste, limited by central office capacity or by relocation of a central office.
 - c. Of ownership of all telephone numbers and prohibits the reassignment or resale of a telephone number by any customer.
4. The Company shall in no event be liable to any customer for direct, indirect or consequential damages caused by failure of service, change of number or assignment of a requested number to another customer whether prior to or after establishment of service. In no event shall the Company be liable to any person, firm or corporation for any amount greater than such person, firm or corporation has actually paid to the Company for the Custom Number Services.
5. Requests for a specific telephone number will be granted providing the requested telephone number is available, e.g., not assigned to a current customer, ready to be assigned and no equipment limitations exist. Requests for a specific telephone number will be honored on a first-come first-served basis.
6. In the event that a request for a specific number is granted and that number is inadvertently assigned to some other customer, the liability of the Company is limited to a refund of any nonrecurring charges paid for that number by the customer whose request could not be fulfilled. The rules and regulations specified in Section 2 for assigning of numbers are also applicable.

NOTICE

THE INFORMATION CONTAINED IN THIS DOCUMENT IS SUBJECT TO CHANGE.

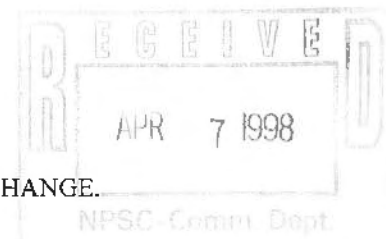

ARAPAHOE TELEPHONE COMPANY

Exchange and Network
Services Catalog

SECTION 5

Page 35

Release 1

State of Nebraska
Notified: 12-19-96

Effective: 1-2-97

5.EXCHANGE SERVICES

C. Rates and Charges

	USOC	NONRECURRING CHARGE
Each number requested and provided		
Residence	RNCSP	\$ 75.00
Business	RNCSP	250.00

5.6 OPERATOR SERVICES

5.6.1 INTERCEPT- SERVICES

A. Description

Intercept Services provide new number or explanatory information to callers dialing changed or disconnected numbers. They include messages delivered either mechanically or by operator.

Basic Intercept

Includes all intercept recordings. Residential customers shall receive basic intercept for a period of up to 2 months Business customers shall receive basic intercept for a period of up to 6 months.

Additional Line Intercept

Provides a number referral message on the first additional line and all subsequent additional lines for business and residential customers. Additional Line Intercept Rates should be applied.

B. Terms and Conditions

1. Basic Intercept is available for residential or business customers. The duration of intercept may vary. Message selection may be restricted in some cases.
2. Basic Intercept, Additional Line Intercept, and Operator Handled Intercept are subject to the availability of facilities and availability of the disconnected number. The Company reserves the right to establish time constraints upon these services. The Company also reserves the right to revoke any intercept service in the event of nonpayment.
3. The Company will be held harmless from any claims which may arise out of the Company's provision of Intercept Service.

C. Rates and Charges

NOTICE

THE INFORMATION CONTAINED IN THIS DOCUMENT IS SUBJECT TO CHANGE.

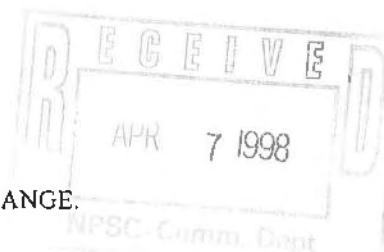

ARAPAHOE TELEPHONE COMPANY

Exchange and Network
Services Catalog

SECTION 5

Page 36

Release 1

State of Nebraska
Notified: 12-19-96

Effective: 1-2-97

5. EXCHANGE SERVICES

1. Basic Intercept is provided at no charge.
2. Additional Line Intercept

	USOC	CHARGE
Business, per number 12 months	AW2TX	\$ 20.00
Residence, per number 3 months	AW23X	20.00

NOTICE

THE INFORMATION CONTAINED IN THIS DOCUMENT IS SUBJECT TO CHANGE.

APR 7 1998

ARAPAHOE TELEPHONE COMPANY

Exchange and Network
Services Catalog

SECTION 5

Page 37

State of Nebraska
Notified: 12-19-96

Release 1
Effective: 1-2-97

5. EXCHANGE SERVICES

5.6.2 DIRECTORY ASSISTANCE SERVICE

A. Directory Assistance

1. Description

Directory Assistance Service is defined as furnishing aid in obtaining telephone numbers. The Directory Assistance charges specified in this Catalog apply when a customer within a Nebraska Number Plan Area (NPA) requests the telephone numbers of customers within the same Nebraska NPA.

2. Terms and Conditions

a. Prices specified in 3., following, are not applicable to calls placed from residence telephones where a member of the customer's household has been certified by a qualified authority as unable to use a directory or from the business telephone of a certified customer where other assistance is not available.

- A qualified authority is defined as including doctors of medicine, ophthalmologist, optometrists, registered nurses, therapists, professional staff of hospitals, institutions and public welfare agencies. Certification of physical disability sufficiently severe to prevent reading or using conventional reading materials may also be made by professional librarians or by any person whose competence in this area is acceptable to the Librarian of Congress of the United States.
- This exemption is limited to 100 free calls a month. Any residence or business customer making more than 100 calls a month will be billed at the regular Directory Assistance charge as specified in 3., following. The Directory Assistance provided under this exemption provision is to be used for personal use only and may not be resold.

3. Charges

In locations, including Public Access Line, public, shared and semipublic (coin/coinless) telephones, where the customer has the capability to direct-dial Directory Assistance but chooses to place the call as a customer dialed calling card (mechanized) or operator-assisted station-to-station call, the appropriate operator service charge applies in addition to the Directory Assistance charge.

CHARGE

Dialed calls (maximum of two requests per call)

- | | |
|---|--------|
| • Each call dialed directly by customer | \$0.60 |
| • Each call placed from Public Access Lines, Public, Shared Payphone, and Semipublic (coin/coinless) telephones | 0.35 |

NOTICE

THE INFORMATION CONTAINED IN THIS DOCUMENT IS SUBJECT TO CHANGE.

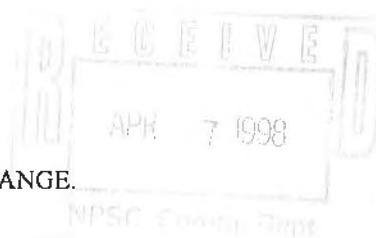

ARAPAHOE TELEPHONE COMPANY

Exchange and Network
Services Catalog

SECTION 5

Page 38

Release 1

State of Nebraska
Notified: 12-19-96

Effective: 1-2-97

5. EXCHANGE SERVICES

5.6.3 SPECIAL REVERSED CHARGE SERVICE

A. Description

Special Reversed Charge Service provides an arrangement whereby customers enable their patrons to call them from points within the customer's LATA where a long distance charge applies, without paying a long distance charge and without requesting that the charge be reversed.

B. Terms and Conditions

1. This service is not available to customers served only by stations equipped with coin collectors.
2. The exchanges in which such service is furnished are selected by the customer, within a single LATA and subject to the approval of the Company. When necessary for the proper operation of the service, the Company assigns and lists in the directory a special call number designation for the use of patrons in each such exchange.
3. Special Reversed Charge Service is available only from stations of the exchanges selected and when a special number designation is used, only those calls placed by calling this special number are considered as coming within the scope of the service.
4. The customer assumes the charges for all long distance calls placed under this plan.
5. The initial contract period for this service is one month.
6. An Operator Station-to-Station service charge applies in connection with Special Reversed Charge Service.
7. Each arrangement provides one listing with a special number which is inserted in a foreign exchange directory. Callers in that foreign exchange may originate long distance messages on an automatically collect basis to the customer for such listing. The operator at the foreign exchange, where the Special Reversed Charge List appears, bills each call collect without further verification to the account of the customer at the terminating exchange.

NOTICE

THE INFORMATION CONTAINED IN THIS DOCUMENT IS SUBJECT TO CHANGE.

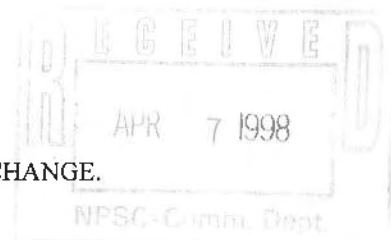

ARAPAHOE TELEPHONE COMPANY

Exchange and Network
Services Catalog

SECTION 5

Page 39

Release 1

State of Nebraska
Notified: 12-19-96

Effective: 1-2-97

5. EXCHANGE SERVICES

C. Rates and Charges

The monthly rates and charges for Special Reversed Charge Service and associated additional listings are as follows:

	USOC	NONRECURRING CHARGE	MONTHLY RATE
• Special Reversed Charge Service[1]	ENT	\$ 20.00	\$ 3.00
• Additional Listings, each[2]	N/A	[3]	[3]

[1] Including primary listings in the alphabetical directory of the exchange involved.

[2] In any alphabetical directory of the exchange in which the related Special Charge Service is provided

[3] See 5.6.1.

NOTICE

THE INFORMATION CONTAINED IN THIS DOCUMENT IS SUBJECT TO CHANGE.

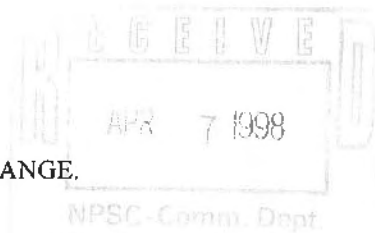

ARAPAHOE TELEPHONE COMPANY

Exchange and Network
Services Catalog

SECTION 5

Page 40

Release 1

State of Nebraska
Notified: 12-19-96

Effective: 1-2-97

5.EXCHANGE SERVICES

5.6.4 OPERATOR VERIFICATION SERVICE

A. Description

Customers may obtain assistance in determining if a called line is in use (herein called verification) or in interrupting a conversation in progress (herein called interrupt) by calling the "O" operator. This service applies to local and long distance calls, where facilities permit.

B. Terms and Conditions

1. A verification charge applies each time the operator verifies a called line and hears a voice communication.
2. An interrupt charge applies each time an operator interrupts a conversation that is in progress on the called line.
3. No request will be processed on a collect or reversal of charge basis.
4. Charges do not apply if the line situation indicates a trouble condition or when the request is identified as an emergency by the customer and originates from or to emergency agencies, such as police, fire, rescue, or ambulance.
5. If an operator both verifies the condition of the line and interrupts conversation on the same request, the interrupt charge only applies.

C. Charges

The charges shown below are in addition to the rates and charges associated with local or long distance calls.

CHARGES

- | | |
|-----------------------------|--------|
| • Verification, per request | \$3.00 |
| • Interrupt, per request | 6.00 |

NOTICE

THE INFORMATION CONTAINED IN THIS DOCUMENT IS SUBJECT TO CHANGE.

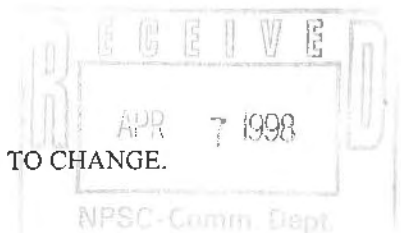

ARAPAHOE TELEPHONE COMPANY.

Exchange and Network
Services Catalog

SECTION 8

Page 1

Release 1

State of Nebraska
Notified: 05-01-2014

Effective: 07-02-2014

8. ACCESS SERVICE

8. Digital Subscriber Line Access Services

Where offered under this tariff, Digital Subscriber Line Access Services provide transmission services over local exchange service facilities that can be used for simultaneous voice and data communications. Service is provided, where available, between customer designated premises and designated Telephone Company Serving Wire Centers.

8.1 Asymmetric Digital Subscriber Line Access Service

8.1.1 General

Asymmetric Digital Subscriber Line (ADSL) Access Service enables data traffic generated by a customer-provided modem to be transported to a DSL Access Service Connection Point using the Telephone Company's local exchange service facilities. A DSL Access Service Connection Point is an interconnection point designated by the Telephone Company in the NATIONAL EXCHANGE CARRIER ASSOCIATION, INC. Tariff F.C.C. No.4 at which the customer may interconnect its ADSL Access Service provided by the Telephone Company under this tariff or its wireline broadband Internet transmission service provided on a non-tariffed, common carrier basis with the tariffed, interstate access services described below. The DSL Access Service Connection Point aggregates ADSL Access Service and/or wireline broadband Internet transmission service data traffic from and to suitably equipped Telephone Company Serving Wire Centers (SWCs). The DSL Access Service Connection Point may be located within the operating territory of the Telephone Company for connections to Special Access Services, Frame Relay Access Service, Asynchronous Transfer Mode Cell Relay Access Service (ATM-CRS) or Ethernet Transport Service (ETS). As specified below, the DSL Access Service Connection Point may also be located in the operating territory of another telephone company for connections to special access services, frame relay access service, or Ethernet access service, provided both telephone companies agree to such an arrangement.

When both the ADSL-equipped SWC and its associated DSL Access Service Connection Point are located within the Telephone Company's operating territory, the customer's ADSL Access Service must be connected to the customer designated premises of a single telecommunications service provider (TSP) using the Telephone Company's Special Access Services, Frame Relay Access Service, ATM-CRS, or ETS provided under this tariff.

When both the ADSL-equipped SWC from which the Telephone Company provides local exchange and exchange access services and its associated DSL Access Service Connection Point are located in the operating territory of an adjacent telephone company, the customer's ADSL Access Service must be connected to the customer designated premises of a single TSP using either equivalent special access service, frame relay access service or Ethernet access service provided by the other telephone company.

When the ADSL-equipped SWC is located within the Telephone Company's operating territory and its associated DSL Access Service Connection Point is located in the

MAY - 2 2014

mm. dept.

ARAPAHOE TELEPHONE COMPANY.

Exchange and Network
Services Catalog

SECTION 8

Page 2

Release 1

State of Nebraska
Notified: 05-01-2014

Effective: 07-02-2014

8. ACCESS SERVICE

operating territory of an adjacent telephone company, the customer's ADSL Access Service must be connected to the customer designated premises of a single TSP using either: 1) equivalent frame relay access service provided by the other telephone company, 2) a combination of DSL Extended Transport provided by the Telephone Company under this tariff and equivalent special access service provided by the other telephone company, or 3) a combination of DSL Extended Transport provided by the Telephone Company under this tariff and equivalent Ethernet access service provided by the other telephone company.

When the ADSL-equipped SWC is located within the Telephone Company's operating territory and its associated DSL Access Service Connection Point is located in the operating territory of a non-adjacent telephone company, the customer's ADSL Access Service must be connected to the customer designated premises of a single TSP using either: 1) equivalent frame relay access service provided by the other telephone company or 2) a combination of DSL Extended Transport provided by the Telephone Company under this tariff and equivalent special access service provided by the other telephone company.

Where technically feasible, ADSL Access Service is available as two service options, i.e., ADSL Voice-Data and ADSL Data-Only.

- (A) The ADSL Voice-Data option provides transmission of data signals using the Telephone Company's existing local exchange service line at peak data transmission speeds of 1 Mbps upstream/6 Mbps downstream, 3 Mbps upstream/15 Mbps downstream, 25 Mbps upstream/50 Mbps downstream, or 50 Mbps upstream/100 Mbps downstream. The ADSL Voice-Data option may be used for simultaneous voice and data communications.
- (B) The ADSL Data-Only option provides transmission of data signals using the Telephone Company's existing local exchange facilities at peak transmission speeds of 1 Mbps upstream/6 Mbps downstream, 3 Mbps upstream/15 Mbps downstream or 5 Mbps upstream/50 Mbps downstream. The ADSL Data-Only option does not provide the ability to transmit voice communications.

A generic view of how ADSL Access Service could be interconnected with a TSP's network is depicted in the figures following. In the first example, the customer's ADSL-equipped Serving Wire Center and associated DSL Access Service Connection Point are located in the same office within the Telephone Company's operating territory. The ADSL Access Service customer orders ADSL Access Service pursuant to the provisions specified in this section. The ADSL Access Service customer's TSP orders Special Access Services, Frame Relay Access Service, Asynchronous Transfer Mode Cell Relay Access Service (ATM-CRS) and/or Ethernet Transport Service (ETS) pursuant to the provisions specified in Section 7, preceding, and Sections 16.1, 16.2 and 16.3, following, to connect its customer designated premises to the DSL Access Service Connection Point.

ARAPAHOE TELEPHONE COMPANY.

Exchange and Network
Services Catalog

SECTION 8

Page 3

Release 1

State of Nebraska
Notified: 05-01-2014

Effective: 07-02-2014

8. ACCESS SERVICE

ADSL ACCESS SERVICE

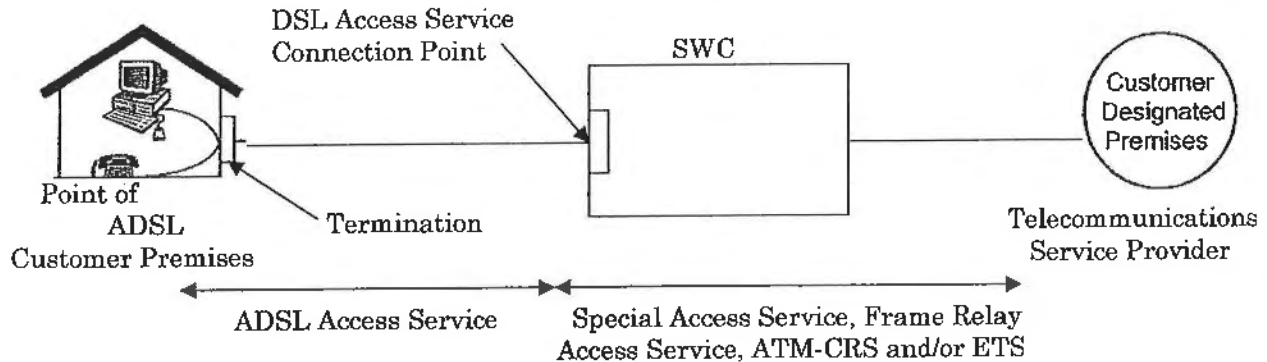

In the example shown below, the DSL Access Service Connection Point is located outside the Telephone Company's operating territory in an adjacent telephone company's operating territory and the customer's TSP uses special access service to connect its CDP to that DSL Access Service Connection Point. The ADSL Access Service customer orders ADSL Access Service pursuant to the provisions specified in this section. In order to connect its customer designated premises to the DSL Access Service Connection Point, the ADSL Access Service customer's TSP orders DSL Extended Transport from the Telephone Company as specified in this section and equivalent special access service from the adjacent telephone company.

ADSL ACCESS SERVICE

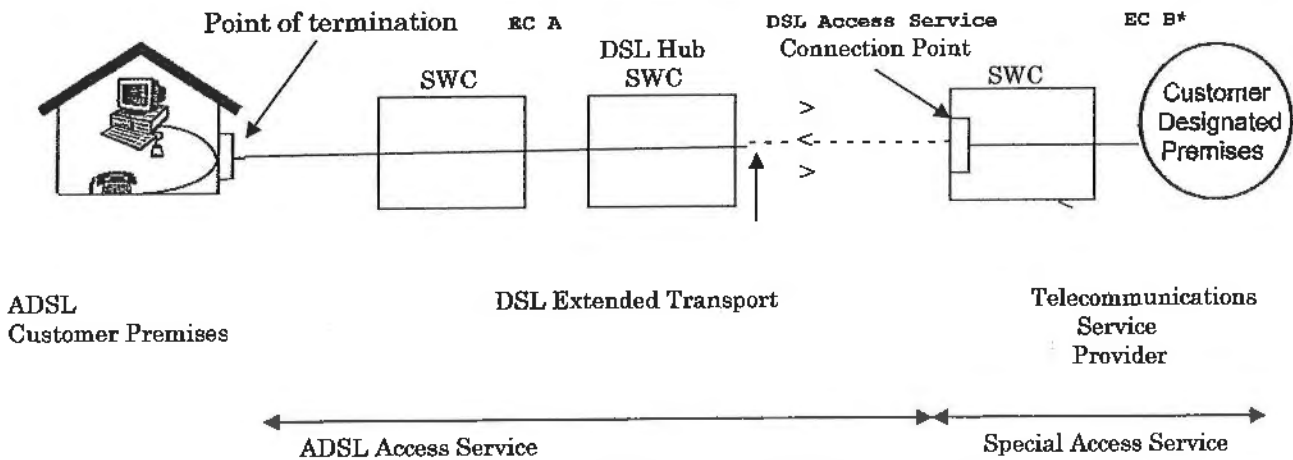

*If EC B is a non-NECA company, the application of their charges will depend on their access tariff

In the example shown below, the DSL Access Service Connection Point is located outside of the Telephone Company's operating territory in the operating territory of an adjacent telephone company and the customer's TSP uses Ethernet access service to connect its CDP to that DSL Access Service Connection Point. The ADSL Access Service customer orders ADSL Access Service pursuant to the provisions specified in this section. In order to connect its customer designated premises to the DSL Access Service Connection Point, the ADSL Access Service customer's TSP

MAY - 2 2014



ARAPAHOE TELEPHONE COMPANY.

Exchange and Network
Services Catalog

SECTION 8

Page 4

Release 1

State of Nebraska
Notified: 05-01-2014

Effective: 07-02-2014

8. ACCESS SERVICE

orders DSL Extended Transport from the Telephone Company as specified in this section and equivalent Ethernet access service from the adjacent telephone company.

ADSL ACCESS SERVICE

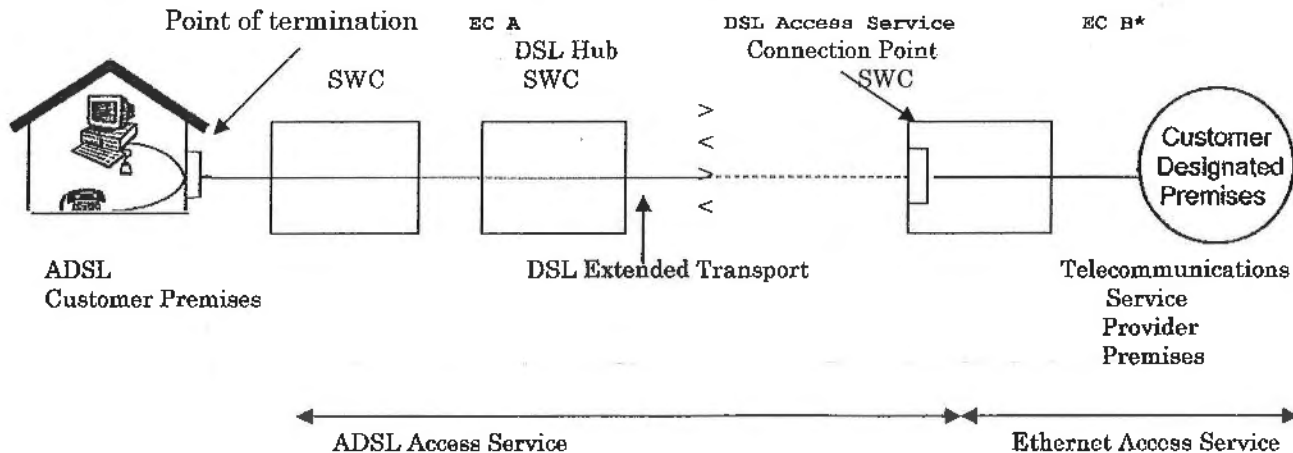

*If EC B is a non-NECA company, the application of their charges will depend on their access tariff

8.1.2 Limitations

(A) Except as described in Section 8.1.1, preceding, ADSL Access Service is available as two service options. Where suitable facilities exist, the Telephone Company will offer ADSL Access Service at the following maximum upstream (i.e., from the customer's equipment up to the DSL Access Service Connection Point) and downstream (i.e., from the DSL Access Service Connection Point down to the customer's equipment) speeds:

(1) 1 Mbps upstream/6 Mbps downstream in compliance with the requirements specified in Technical References

ATIS-0600413.2009,
ITU-T G.983.1-January 2005,
ITU-T G.983.2-July 2005,
ITU-T G.983.3-March 2001,
ITU-T G.983.4-November 2001,
ITU-T G.984.1-March 2008,
ITU-T G.984.2-March 2003,
ITU-T G.984.3-March 2008,
ITU-T G.984.4-February 2008,
ITU-T G.992.1-June 1999,
ITU-T G.992.3-January 2005,
ITU-T G.992.4-July 2002,
ITU-T G.992.5-January 2005,
ITU-T G.993.1-June 2004,
ITU-T G.993.2-February 2006,
and/or IEEE Std. 802.3-2008, Part 3, Section 5,
Clauses 56 through 67, unless otherwise
specified in Section 8.1.6, following.

ARAPAHOE TELEPHONE COMPANY.

Exchange and Network
Services Catalog

SECTION 8

Page 5

Release 1

State of Nebraska
Notified: 05-01-2014

Effective: 07-02-2014

8. ACCESS SERVICE

(2) 3 Mbps upstream/1S Mbps downstream in compliance with the requirements specified in Technical References

ITU-T G.983.1-January 2005,
ITU-T G.983.2-July 2005,
ITU-T G.983.3-March 2001,
ITU-T G.983.4-November 2001,
ITU-T G.984.1-March 2008,
ITU-T G.984.2-March 2003,
ITU-T G.984.3-March 2008,
ITU-T G.984.4-February 2008,
ITU-T G.992.5-January 2005,
ITU-T G.993.1-June 2004,
ITU-T G.993.2-February 2006,
and/or IEEE Std. 802.3-2008, Part 3, Section 5,
Clauses 56 through 67.

(3) 5 Mbps upstream/50 Mbps downstream, 25 Mbps upstream/50 Mbps downstream, or 50 Mbps 1 upstream/10a Mbps downstream in compliance with the requirements specified in Technical References

ITU-T G.983.1-January 2005,
ITU-T G.983.2-July 2005,
ITU-T G.983.3-March 2001,
ITU-T G.983.4-November 2001,
ITU-T G.984.1-March 2008,
ITU-T G.984.2-March 2003,
ITU-T G.984.3-March 2008,
ITU-T G.984.4-February 2008,
ITU-T G.993.1-June 2004,
ITU-T G.993.2-February 2006,
and/or IEEE Std. 802.3-2008, Part 3, Section 5,
clauses 56 through 67.

These peak speeds are not guaranteed by the Telephone Company due to factors that may affect the actual speeds delivered, including the ADSL Access Service customer's distance from the Telephone Company Serving Wire Center, condition of the existing exchange service facilities, and any capacity limitations in the TSP's network design.

(B) The Telephone Company does not provide customer premises equipment (CPE) in conjunction with the ADSL Access Service offering.

(C) ADSL Access Service may not be used in conjunction with multi-point Special Access Service configurations as described in Section 7.1.3, preceding.

(D) ADSL Access Service will be furnished where suitable facilities exist as determined by the Telephone Company. The Telephone Company will identify its ADSL-equipped Serving Wire Centers, DSL Access Service Connection Point Serving Wire Centers, and, if applicable, DSL Transport Hub Serving Wire Centers in the NATIONAL EXCHANGE CARRIER ASSOCIATION, INC. Tariff F.C.C. No.4.

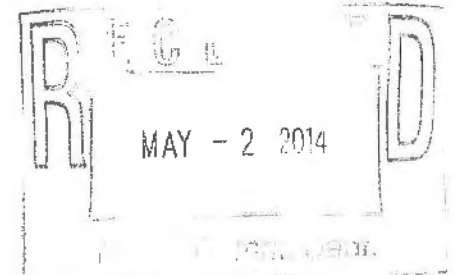

ARAPAHOE TELEPHONE COMPANY.

Exchange and Network
Services Catalog

SECTION 8

Page 6

Release 1

State of Nebraska
Notified: 05-01-2014

Effective: 07-02-2014

8. ACCESS SERVICE

(E) ADSL Access Service will be provided over existing (T) Telephone Company local exchange service facilities. When the customer orders the ADSL Voice-Data option, the rates and regulations for ADSL Access Service are in addition to any rates and regulations that apply for the associated local exchange service line provided under the terms and conditions in the Telephone Company's general and/or local exchange service tariffs. The Telephone Company will automatically disconnect the ADSL Access Service Voice-Data option when the associated local exchange service line is disconnected for any reason.

(F) Rates and regulations for Special Access Services, Frame Relay Access Service, Asynchronous Transfer Mode Cell Relay Access Service and Ethernet Transport Service provided under this tariff will apply for the access service(s) provided between the TSP's customer designated premises and the DSL Access Service Connection Point, as described in the National Exchange Carrier Association, Inc. Tariff FCC No. 4 in Section 71, and Sections 16.1, 16.2 and 16.3.

8.1.3 Undertaking of the Telephone Company

Where technically feasible, the Telephone Company will offer ADSL Access Service as described in Section 8.1.2, preceding. The Telephone Company will provide ADSL Access Service at rates and charges as set forth in the National Exchange Carrier Association, Inc. Tariff FCC No. 4 in Sections 17.4.9(A) and/or 17.4.9(H), as follows:

(A) The Telephone Company will determine if the associated local exchange service line or facilities are suitable for use with the ADSL Access Service option ordered by the customer. Service will not be provided on lines that the Telephone Company determines are not suitable for ADSL Access Service or on lines that produce interference with other services provided by the Telephone Company.

(B) The Telephone Company, after determining if the facilities are suitable for ADSL Access Service, will notify the customer if any additional CPE is necessary to support ADSL Access Service.

(C) The Telephone Company will provision and maintain ADSL Access Service from the DSL Access Service Connection Point to the Point of Termination at the ADSL Access Service customer's premises, except as provided for in Section 8.1.5(D), following.

(D) The Telephone Company will notify the ADSL Access Service customer's TSP when DSL Extended Transport, as described in Section 8.1.5(D), following, is required.

The Telephone Company specific rate band assignment for ADSL Access Service is specified in the A/SDSL Rate Band column the National Exchange Carrier Association, Inc. Tariff FCC No. 4 in Section 17.6(A).

8.1.4 Obligations of the Customer

ARAPAHOE TELEPHONE COMPANY.

Exchange and Network
Services Catalog

SECTION 8

Page 7

Release 1

State of Nebraska

Notified: 05-01-2014

Effective: 07-02-2014

8. ACCESS SERVICE

In addition to the regulations described in other sections of this tariff, the following provisions apply to ADSL Access Service:

(A) The customer is responsible for providing the Telephone Company with the necessary information to provision ADSL Access Service (e.g., customer name telephone number and premises address; billing name and address when different from the customer name and premise address; its internet Protocol (IP) address; and the contact name and telephone number of the TSP with which the customer's ADSL Access Service will interconnect).

(B) The customer is responsible for providing and maintaining all required CPE, which is compatible with ADSL Access Service and complies with the applicable Technical References specified in Section 8.1.2(A), preceding.

(C) Where required, the ADSL Access Service customer's TSP will order DSL Extended Transport from each Telephone Company designated DSL Transport Hub to its associated DSL Access Service Connection Point as described in Section 8.1.5(D), following.

8.1.5 Rate Regulations

This section contains the regulations governing the rates and charges that apply for ADSL Access Service. Regulations governing the rates and charges for the Special Access Services, Frame Relay Access Service, Asynchronous Transfer Mode Cell Relay Access Service and Ethernet Transport Service provided under this tariff used in conjunction with ADSL Access Service are as specified in the National Exchange Carrier Association, Inc. Tariff FCC No. 4 in Section 7 and Sections 16.1, 16.2 and 16.3.

(A) Minimum Period

The minimum period for which ADSL Access Service is provided to a customer and for which charges are applicable is one month.

(B) Moves

A move involves a change in the physical location of one of the following:

- The Point of Termination at the ADSL Access Service customer designated premises
- The ADSL Access Service customer designated premises

The provisions for moves of ADSL Access Service are the same as those described in the National Exchange Carrier Association, Inc. Tariff FCC No. 4 in Section 7.2.3, except that an Access Order Charge will not apply to move orders for the ADSL Access Service Voice-Data option.

(C) Temporary Suspension of Service*

When an end user temporarily suspends the local exchange service that is associated with an ADSL Voice-Data option, the ADSL Voice-Data option will also be placed on temporary suspension for the same period of time, and the Telephone Company will bill the customer a temporary suspension fee, per line, per occasion, as described in the National Exchange Carrier Association, Inc. Tariff FCC No. 4 in Section 17.4.9 (C). The Telephone Company will not bill the customer the monthly ADSL Voice-Data Line

MAY - 2 2014

ARAPAHOE TELEPHONE COMPANY.

Exchange and Network
Services Catalog

SECTION 8

Page 8

Release 1

State of Nebraska
Notified: 05-01-2014

Effective: 07-02-2014

8. ACCESS SERVICE

Charge while the ADSL Voice-Data option is placed on temporary suspension.

(D) DSL Extended Transport

DSL Extended Transport is required when: 1) the Telephone Company providing ADSL Access Service locates its DSL Access Service Connection Point outside its operating territory in the operating territory of another telephone company and 2) the ADSL Access Service customer's TSP connects its customer designated premises to the DSL Access Service Connection Point using Special Access Service described in the National Exchange Carrier Association, Inc. Tariff FCC No. 4 in Section 7, or equivalent special access service provided by the other telephone company.

DSL Extended Transport is also required when: 1) the Telephone Company providing ADSL Access Service locates its DSL Access Service Connection Point outside its operating territory in the operating territory of an adjacent telephone company and 2) the ADSL Access Service customer's TSP connects its customer designated premises to the DSL Access Service Connection Point using Ethernet Transport Service described in the National Exchange Carrier Association, Inc. Tariff FCC No. 4 in Section 16.3, following, or equivalent Ethernet access service provided by the adjacent telephone company.

* The nonrecurring temporary suspension fee, as described in the National Exchange Carrier Association, Inc. Tariff FCC No. 4 in Section 17.4.9 (C), following, will not apply to existing customers who temporarily suspended their ADSL Voice-Data service prior to December 20, 2011.

DSL Extended Transport provides the TSP with a virtual circuit path between a Telephone Company-designated DSL Transport Hub and its associated DSL Access Service Connection Point location. The Telephone Company must designate at least one DSL Transport Hub SWC location within its operating territory when it locates a DSL Access Service Connection Point outside its operating territory. The DSL Transport Hub aggregates ADSL and/or SDSL Access Services data traffic within the operating territory of the Telephone Company providing the DSL Access Service.

DSL Extended Transport is available between: 1) a DSL Transport Hub SWC and its associated DSL Access Service Connection Point SWC located within the United States when the ADSL customer's TSP connects its CDP to the DSL Access Service Connection Point using special access services, 2) a DSL Transport Hub SWC and a cross border connection point located within the United States when the Telephone Company has located its associated DSL Access Service Connection Point in Canada and the ADSL customer's TSP connects its CDP to the DSL Access Service Connection Point using special access services, and 3) a DSL Transport Hub SWC and its associated DSL Access Service Connection Point SWC located in an adjacent telephone company's operating territory when the ADSL customer's TSP connects its CDP to the DSL Access Service Connection Point using Ethernet access service.

Where required, DSL Extended Transport is used to transmit AOSL and/or SOSL data traffic. OSL Extended Transport is available at a speed of 1.544

ARAPAHOE TELEPHONE COMPANY.

Exchange and Network
Services Catalog

SECTION 8

Page 9

Release 1

State of Nebraska
Notified: 05-01-2014

Effective: 07-02-2014

8. ACCESS SERVICE

Mbps when used in conjunction with special access service and at speeds of 2 Mbps, 5 Mbps, 10 Mbps, 20 Mbps, 50 Mbps, 100 Mbps, 250 Mbps, 500 Mbps, 750 Mbps, 1 Gbps, 2.5 Gbps, 5 Gbps and 10 Gbps when used in conjunction with Ethernet access service. The TSP is responsible for determining and ordering the number of DSL Extended Transport virtual circuit paths it requires to meet its end users' data transmission needs. The TSP must place an order for at least one 1.544 Mbps OSL Extended Transport virtual circuit path, where required, when it places the order for Special Access Service (or equivalent special access service) to connect its customer designated premises to the DSL Access Service Connection Point. The TSP must place an order for at least one 2 Mbps DSL Extended Transport virtual circuit path, where required, when it places the order for Ethernet Transport Service (or equivalent Ethernet access service) to connect its customer designated premises to the DSL Access Service Connection Point. An Access Order Charge applies per order for the installation of DSL Extended Transport.

When the DSL Access Service Connection Point is located in Canada, DSL Extended Transport will be furnished by the Telephone Company to a cross border connection point located in the United States. DSL Extended Transport from the cross border connection point to the DSL Access Service Connection Point will be provided by the Canadian telephone company. The Telephone Company will work cooperatively with the TSP and Canadian telephone company for the provisioning of DSL Extended Transport in Canada. Rates and regulations defined in this section only apply to that portion of the service between the DSL Transport Hub and the cross border connection point.

(1) Mileage Measurement

(a) The mileage to be used to determine the monthly charges for each DSL Extended Transport virtual circuit path is calculated using the airline distance between each DSL Transport Hub and its associated DSL Access Service Connection Point when both locations are within the United States. To determine the applicable monthly charges, first compute the mileage using the V&H coordinates method, as described in the NATIONAL EXCHANGE CARRIER ASSOCIATION, INC. TARIFF F.C.C. No.4. When the calculation results in a fraction of a mile, always round up to the next whole mile before determining the total mileage and applying the rates. Once the total mileage for each path is determined, multiply the number of miles times the DSL Extended Transport per mile rates specified in the National Exchange Carrier Association, Inc. Tariff FCC No. 4 in Section 17.4.9(F), following.

The Telephone Company specific rate band assignment for DSL Extended Transport is specified in the DSL Extended Transport Rate Band column in the National Exchange Carrier Association, Inc. Tariff FCC No. 4 in Section 17.6(A). The following example is an illustrative model, only provided for the purpose of clarification. Actual charges will vary, dependent upon the effective DSL Extended Transport per mile rates specified in the National Exchange Carrier Association, Inc. Tariff FCC No. 4 in Section 17.4.9(F).

MAY - 2 19
M - 2 - 2014
M - 2 - 2014

ARAPAHOE TELEPHONE COMPANY.

Exchange and Network
Services Catalog

SECTION 8

Page 10

Release 1

State of Nebraska
Notified: 05-01-2014

Effective: 07-02-2014

8. ACCESS SERVICE

Example:

- TSP orders two 1.544 Mbps DSL Extended Transport paths between a DSL Transport Hub SWC and the associated DSL Access Service Connection Point SWC. Both SWCs are located within the United States.
- Total mileage between the SWCs is calculated at 28.4 miles.

Monthly charges for DSL Extended Transport are determined as follows:

- Telephone Company specific rate band assignment for DSL Extended Transport is Rate Band 1.
- Fractional mileage rounded up to the next whole mile equals 29 miles.
- First 25 miles x \$0.00 per mile equals \$0.00 per path.
- Next four miles x \$11.00 per mile equals \$44.00 per path.
- Total mileage charges for DSL Extended Transport in this example equal \$88.00 per month (i.e., \$44.00 x two paths).

(b) The mileage to be used to determine the monthly charges for each DSL Extended Transport virtual circuit path between a DSL Transport Hub and a cross border connection point is specified below. To calculate the monthly charges for each path, multiply the number of miles between the DSL Transport Hub and the cross border connection point times the DSL Extended Transport per mile rates specified in Section 17.4.9(F), following. The portion of the DSL Extended Transport furnished from the cross border connection point to the DSL Access Service Connection Point is the responsibility of the TSP and is not covered in this tariff as described in Section 8.1.5(0), above.

(i) The number of miles to be used for rating DSL Extended Transport provided under this tariff between the Ketchikan Public Utilities DSL Transport Hub SWC and the Garnet Point, AK cross border connection point is 60 miles.

(E) Rate Categories

There are two types of rates and charges applicable to ADSL Access Service. These are monthly rates and nonrecurring charges.

The monthly rate for the ADSL Line Charge applies each month or fraction thereof for each ADSL Voice-Data option and ADSL Data-Only option ordered by the customer. The monthly rate for DSL Extended Transport applies each month or fraction thereof for each virtual circuit path as described in Section 8.1.5(D), preceding.

A nonrecurring charge applies for each ADSL Voice-Data and ADSL Data-Only option ordered by the customer for the installation of ADSL Access Service. The nonrecurring installation charge will be waived for each new ADSL Voice-Data option and ADSL Data-Only option Access Line ordered when the customer commits to retain the ADSL Access Line for a minimum period of 6 months

ARAPAHOE TELEPHONE COMPANY.

Exchange and Network
Services Catalog

SECTION 8

Page 11

Release 1

State of Nebraska
Notified: 05-01-2014

Effective: 07-02-2014

8. ACCESS SERVICE

following installation of service. If the ADSL Access Line is disconnected for any reason prior to the end of the 6-month minimum commitment period other than for:

- an ADSL service conversion as described below,
- a discontinuance of service within the first 30 days of service as described below, or
- a discontinuance of service due to a fire, flood or other occurrence as described below;

The Telephone Company will bill the customer an early termination fee, as described in the National Exchange Carrier Association, Inc. Tariff FCC No. 4 in Section 17.4.9(D), for each ADSL Voice-Data and Data-Only option disconnected by the customer, prior to satisfying the 6-month minimum commitment period. Existing ADSL Voice-Data and Data-Only customers as of December 20, 2011, who are committed to a not yet concluded 12-month minimum service period but have had service for at least 6 months, are considered to have met their commitment period for waiver of the nonrecurring installation charge.

Existing ADSL Voice-Data and Data-Only customers as of December 20, 2011, who have not yet completed 6 months of service will be covered under the new 6-month minimum commitment. The early termination fee, as described in the National Exchange Carrier Association, Inc. Tariff FCC No. 4 in Section 17.4.9 (D), will apply should service be disconnected prior to the end of the 6-month minimum commitment period.

Except as otherwise specified in Section 8.1.5(E), below, changes to an existing ADSL Access Service will be treated as a discontinuance of the existing service and an installation of a new service. Such changes include an ADSL service conversion or a change of TSP. A nonrecurring installation charge will apply per ADSL Access Service line for this work activity.

ADSL service conversions include change of a service option (i.e., replacing ADSL Voice-Data with ADSL Data-Only, or vice versa), any change of a speed level (e.g., replacing ADSL Voice-Data 1 Mbps with ADSL Voice-Data 3 Mbps), or any combination of a simultaneous change of service option and speed level (e.g., replacing ADSL Voice-Data 1 Mbps with ADSL Data-Only 3 Mbps). When a customer orders an ADSL service conversion but has not met its 6-month minimum commitment on the existing ADSL service, the Telephone Company will not bill the early termination fee for the original ADSL service, if the customer commits to a new minimum 6-month period for the newly converted ADSL service.

Any existing customer who, as of May 2, 2012, had a speed option that is no longer available after May 3, 2012, will be automatically converted to the next higher speed option by the Telephone Company without having to re-order service. This is considered a Telephone Company initiated conversion and therefore any applicable Access Order Charge or nonrecurring installation charge would not apply. In addition, for any customer who is

MAY - 2 2014

NPSC-Comm. Unit.

ARAPAHOE TELEPHONE COMPANY.

Exchange and Network
Services Catalog

SECTION 8

Page 12

Release 1

State of Nebraska
Notified: 05-01-2014

Effective: 07-02-2014

8. ACCESS SERVICE

converted to a higher speed option by the Telephone Company under this provisional service will continue uninterrupted and the ADSL Line Charge Early Termination Fee will not apply if the customer has not yet satisfied a previously committed to 6-month minimum period on the original lower speed option.

For an ADSL customer who disconnects service within the first 30 days following installation, the Telephone Company will not bill the customer the early termination fee provided: 1) the customer had not previously had ADSL Access Service at the same location within the 30 days immediately prior to installing service and 2) the customer's ADSL Access Service is disconnected by no later than the first business day following the 30th day after service was installed.

When a customer disconnects its ADSL Access Service prior to the expiration of its 6-month minimum commitment as a result of a fire, flood or other occurrence, as described in the National Exchange Carrier Association, Inc. Tariff FCC No. 4 in Section 2.4.5, the Telephone Company will not bill the early termination fee.

The following administrative changes will be made without charge to the customer:

- Change of customer premises address when the change of address is not a result of a physical relocation of equipment,
- Change of the associated local exchange service line over which ADSL Voice-Data Access Service is provided when there is no physical relocation of the ADSL Access Service involved,
- Change in billing data (name, address or contact name or telephone),
- Change of billing account number,
- Change of agency authorization that requires no changes to the Telephone Company's network,
- Change in the ADSL Access Service customer's existing IP address when requested by the customer's TSP,
- Change to limit the data speed delivered over the customer's existing ADSL Access Service line when requested by the customer's TSP, Change of customer contact name or telephone number, and
- Change of jurisdiction.

The nonrecurring installation charge will not apply to restore an ADSL Access Service that was temporarily suspended by the Telephone Company for non-payment of charges.

Rates and charges for ADSL Access Service are as set forth in the National Exchange Carrier Association, Inc. Tariff FCC No. 4 in Section 17.4.9(A), or in Section 17.4.9(H), when the customer purchases ADSL Access Service under the DSL Access Services Wholesale Pricing Plan. The rates for DSL Extended Transport are as set forth in the National Exchange Carrier Association, Inc. Tariff FCC No. 4 in Section 17.4.9(F).

ARAPAHOE TELEPHONE COMPANY.

Exchange and Network
Services Catalog

SECTION 8

Page 13

Release 1

State of Nebraska
Notified: 05-01-2014

Effective: 07-02-2014

8. ACCESS SERVICE

The Telephone Company specific rate band assignment for line charges associated with ADSL Voice-Data and ADSL Data-Only Access Service are specified in the A/SDSL Voice-Data and A/SDSL Data-Only Rate Band columns in the National Exchange Carrier Association, Inc. Tariff FCC No. 4 in Section 17.6(A).

8.2 Symmetric Digital Subscriber Line Access Service

8.2.1 General

Symmetric Digital Subscriber Line (SDSL) Access Service provides the customer the ability to transmit data to (upstream rate) and receive data from (downstream rate) a DSL Access Service Connection Point at the same speed using the Telephone Company's existing local exchange service facilities. A DSL Access Service Connection Point is an interconnection point designated by the Telephone Company in the NATIONAL EXCHANGE CARRIER ASSOCIATION, INC. Tariff F.e.C. No.4 at which the customer may interconnect its SDSL Access Service provided by the Telephone Company under this tariff or its wireline broadband Internet transmission service provided on a non-tariffed, common carrier basis with the tariffed, interstate access services described below. The DSL Access Service Connection Point aggregates SDSL Access Service and/or wireline broadband Internet transmission service data traffic from and to suitably equipped Telephone Company Serving Wire Centers (SWCs). The DSL Access Service Connection Point may be located within the operating territory of the Telephone Company for connections to Special Access Services, Frame Relay Access Service, Asynchronous Transfer Mode Cell Relay Access Service (ATM-CRS) or Ethernet Transport Service (ETS). As specified below, the DSL Access Service Connection Point may also be located in the operating territory of another telephone company for connections to special access services, frame relay access service, or Ethernet access service, provided both telephone companies agree to such an arrangement. When both the SDSL-equipped SWC and its associated DSL Access Service Connection Point are located within the Telephone Company's operating territory, the customer's SDSL Access Service must be connected to the customer designated premises of a single telecommunications service provider (TSP) using the Telephone Company's Special Access Services, Frame Relay Access Service, ATM-CRS, or ETS provided under this tariff.

When both the SDSL-equipped SWC from which the Telephone Company provides local exchange and exchange access services and its associated DSL Access Service Connection Point are located in the operating territory of an adjacent telephone company, the customer's SDSL Access Service must be connected to the customer designated premises of a single TSP using either equivalent special access service, frame relay access service or Ethernet access service provided by the other telephone company.

When the SDSL-equipped SWC is located within the Telephone Company's operating territory and its associated DSL Access Service Connection Point is located in the operating territory of an adjacent telephone company, the customer's SDSL Access Service must be connected to the customer designated premises of a single TSP using either: 1) equivalent frame relay access service provided by the other telephone

MAY - 2 2014

Nebraska Comm. Dept.

ARAPAHOE TELEPHONE COMPANY.

Exchange and Network
Services Catalog

SECTION 8

Page 14

Release 1

State of Nebraska
Notified: 05-01-2014

Effective: 07-02-2014

8. ACCESS SERVICE

company, 2) a combination of DSL Extended Transport provided by the Telephone Company under this tariff and equivalent special access service provided by the other telephone company, or 3) a combination of DSL Extended Transport provided by the Telephone Company under this tariff and equivalent Ethernet access service provided by the other telephone company.

When the SDSL-equipped SWC is located within the Telephone Company's operating territory and its associated DSL Access Service Connection Point is located in the operating territory of a non-adjacent telephone company, the customer's SDSL Access Service must be connected to the customer designated premises of a single TSP using either: 1) equivalent frame relay access service provided by the other telephone company or 2) a combination of DSL Extended Transport provided by the Telephone Company under this tariff and equivalent special access service provided by the other telephone company.

SDSL Access Service is available as two service options, i.e., SDSL Voice-Data and SDSL Data-Only.

- (A) The SDSL Voice-Data option provides transmission of data signals at peak data transmission speeds of 256 kbps or 768 kbps using the Telephone Company's existing local exchange service line. This option may be used for simultaneous voice and data communications.
- (B) The SDSL Data-Only option provides transmission of data signals at peak transmission speeds of 144 kbps, 256 kbps, 768 kbps, 2 Mbps or 4 Mbps using the Telephone Company's existing local exchange facilities. This option does not provide the ability to transmit voice communications.

A generic view of how SDSL Access Service could be interconnected with a TSP's network is depicted in the figures following. In the first example, the customer's SDSL-equipped Serving Wire Center and associated DSL Access Service Connection Point are located in the same office within the Telephone Company's operating territory. The SDSL Access Service customer orders SDSL Access Service pursuant to the provisions specified in this section. The SDSL Access Service customer's TSP orders Special Access Services, Frame Relay Access Service, Asynchronous Transfer Mode Cell Relay Access Service (ATM-CRS) and/or Ethernet Transport Service (ETS) pursuant to the provisions specified in the National Exchange Carrier Association, Inc. Tariff FCC No. 4 in Section 7, and Sections 16.1, 16.2 and 16.3, to connect its customer designated premises to the DSL Access Service Connection Point.

ARAPAHOE TELEPHONE COMPANY.

Exchange and Network
Services Catalog

SECTION 8

Page 15

Release 1

State of Nebraska

Notified: 05-01-2014

Effective: 07-02-2014

8. ACCESS SERVICE

SDSL ACCESS SERVICE

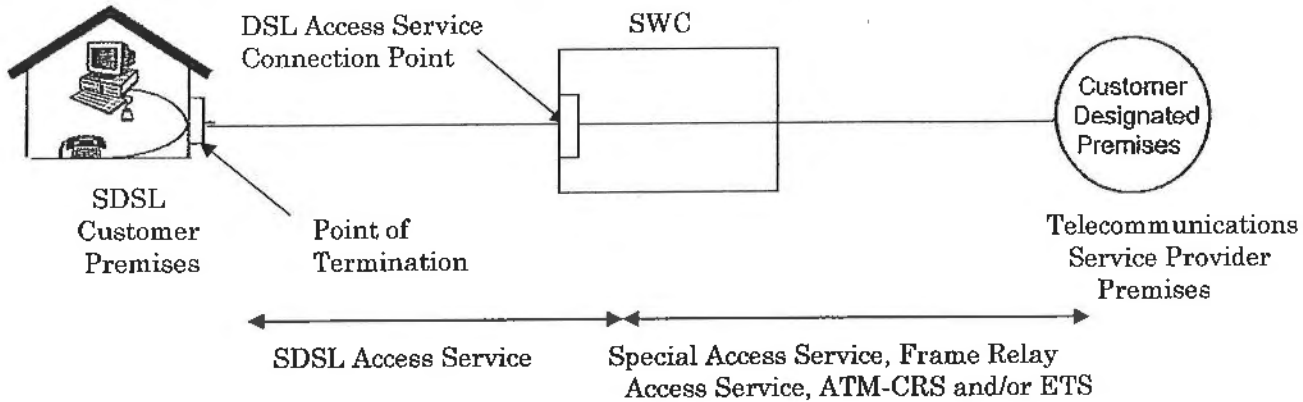

In the example shown below the DSL Access Service Connection Point is located outside the Telephone Company's operating territory in an adjacent telephone company's operating territory and the customer's uses special access service to connect its COP to that DSL Access Service Connection Point. The SDSL Access Service customer orders SDSL Access Service pursuant to the provisions specified in this section. In order to connect its customer designated premises to the DSL Access Service Connection Point, the SDSL Access Service customer's TSP orders DSL Extended Transport from the Telephone Company as specified in this section and equivalent special access service from the adjacent telephone company.

SDSL ACCESS SERVICE

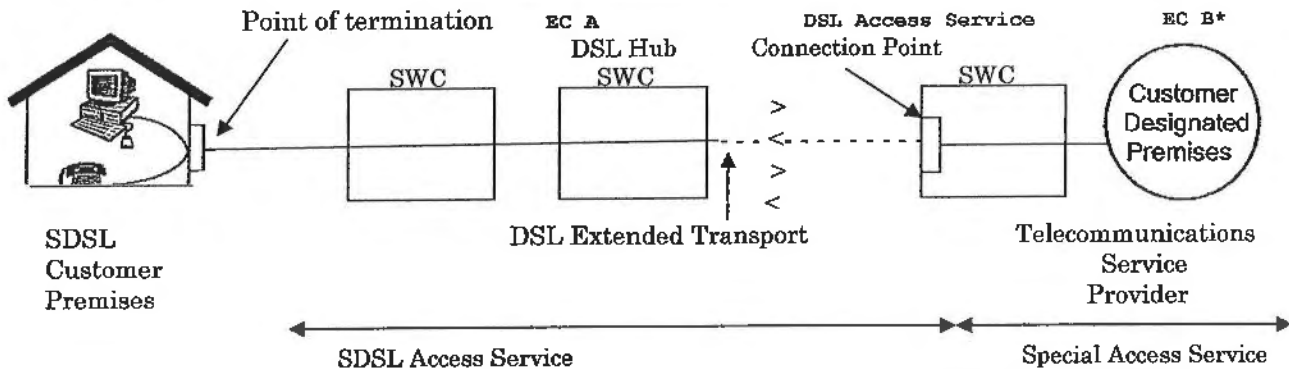

*If EC B is a non-NECA company, the application of their charges will depend on their access tariff

In the example shown below, the DSL Access Service Connection Point is located outside of the Telephone Company's operating territory in the operating territory of an adjacent telephone company and the customer's TSP uses Ethernet access service to connect its CDP to that DSL Access Service Connection Point. The SDSL Access Service customer orders SDSL Access Service pursuant to the provisions specified in this section. In order to connect its customer designated premises to the DSL Access Service Connection Point, the SDSL Access Service customer's TSP orders DSL Extended Transport from the Telephone Company as specified in this section and equivalent Ethernet access service from the adjacent telephone company.

MAY - 2 2014
INFORMATION DEPT.

ARAPAHOE TELEPHONE COMPANY.

Exchange and Network
Services Catalog

SECTION 8

Page 16

Release 1

State of Nebraska
Notified: 05-01-2014

Effective: 07-02-2014

8. ACCESS SERVICE

SDSL ACCESS SERVICE

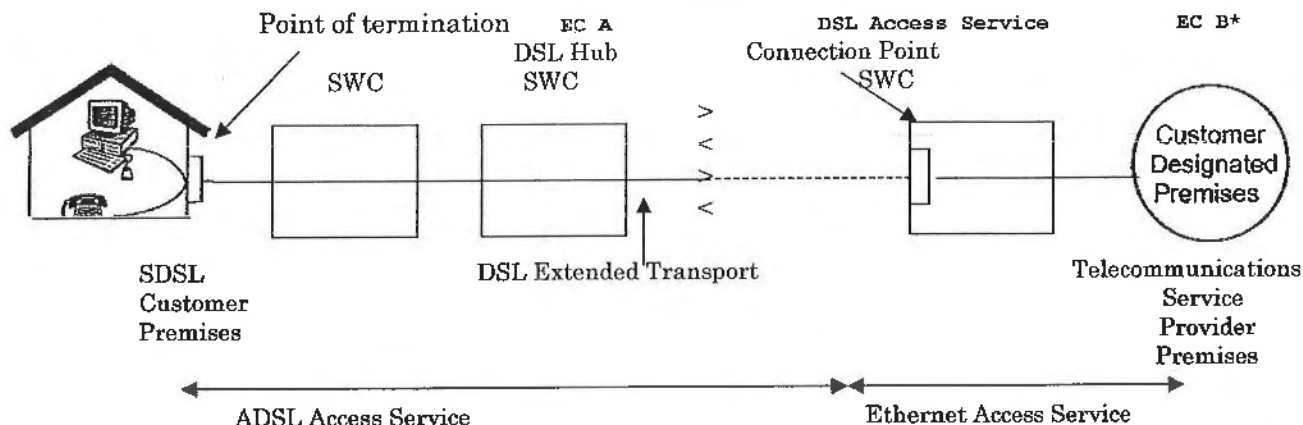

*If EC B is a non-NECA company, the application of their charges will depend on their access tariff

8.2.2 Limitations

SDSL Access Service is available as two service options as described above. Peak speeds are not guaranteed by the Telephone Company due to factors that may affect the actual speeds delivered, including the SDSL Access Service customer's distance from the Telephone Company Serving Wire Center, condition of the existing local exchange service facilities, and any capacity limitations in the TSP's network design.

The Telephone Company does not provide customer premises equipment (CPE) in conjunction with the SDSL Access Service offering.

SDSL Access Service may not be used in conjunction with multi-point Special Access Service configurations as described in the National Exchange Carrier Association, Inc. Tariff FCC No. 4 in Section 7.1.3, preceding.

SDSL Access Service will be furnished where suitable facilities exist as determined by the Telephone Company. The Telephone Company will identify its SDSL-equipped Serving Wire Centers, DSL Access Service Connection Point Serving Wire Centers, and if applicable DSL Transport Hub Serving Wire Centers in the NATIONAL EXCHANGE CARRIER ASSOCIATION, INC. Tariff F.C.C. No.4. The Telephone Companies listed in Section 17.6 of that Tariff, will offer SDSL Access Service under the provisions specified in Section 8.2.

SDSL Access Service will be provided over existing Telephone Company local exchange service facilities. When the customer orders the SDSL Voice-Data option, the rates and regulations for SDSL Access Service are in addition to any rates and regulations that apply for the associated local exchange service line provided under the terms and conditions in the Telephone Company's general and/or local exchange service tariffs. The Telephone Company will automatically disconnect the SDSL Access Service Voice-Data option when the associated local exchange service line is disconnected for any reason.

ARAPAHOE TELEPHONE COMPANY.

Exchange and Network
Services Catalog

SECTION 8

Page 17

Release 1

State of Nebraska
Notified: 05-01-2014

Effective: 07-02-2014

8. ACCESS SERVICE

Rates and regulations for Special Access Services, Frame Relay Access Service, Asynchronous Transfer Mode Cell Relay Access Service and Ethernet Transport Service provided under this tariff will apply for the access service(s) provided between the TSP's customer designated premises and the DSL Access Service Connection Point, as described in the National Exchange Carrier Association, Inc. Tariff FCC No. 4 in Section 7, preceding, and Sections 16.1, 16.2 and 16.3.

8.2.3 Undertaking of the Telephone Company

The Telephone Company will provide SDSL Access Service at the rates and charges set forth in the National Exchange Carrier Association, Inc. Tariff FCC No. 4 in Sections 17.4.9(B) and/or 17.4.9(H), as follows:

(A) The Telephone Company will determine if the associated local exchange service line or facilities are suitable for use with the SDSL Access Service option ordered by the customer. Service will not be provided on facilities that the Telephone Company determines are not suitable for SDSL Access Service or on facilities that produce interference with other services provided by the Telephone Company.

(B) The Telephone Company, after determining if the facilities are suitable for SDSL Access Service, will notify the customer if the customer's CPE is compatible with the equipment deployed in the Telephone Company's Serving Wire Center and if any additional CPE is necessary to support SDSL Access Service.

(C) The Telephone Company will provision and maintain SDSL Access Service from the DSL Access Service Connection Point to the Point of Termination at the SDSL Access Service customer's premises, except as provided for in Section 8.2.5(D), following.

(D) The Telephone Company will notify the SDSL Access Service customer's TSP when DSL Extended Transport, as described in Section 8.2.5(D), following, is required.

The Telephone Company specific rate band assignment for SDSL Access Service is specified in the A/SDSL Rate Band column in the National Exchange Carrier Association, Inc. Tariff FCC No. 4 in Section 17.6(A).

8.2.4 Obligations of the Customer

In addition to the regulations described in other sections of this tariff, the following provisions apply to SDSL Access Service:

(A) The customer is responsible for providing the Telephone Company with the necessary information to provision SDSL Access Service (e.g., customer name, telephone number and premises address; billing name and address when different from the customer name and premises address; its Internet Protocol (IP) address; and the contact name and telephone number of the TSP with which the customer's SDSL Access Service will interconnect).

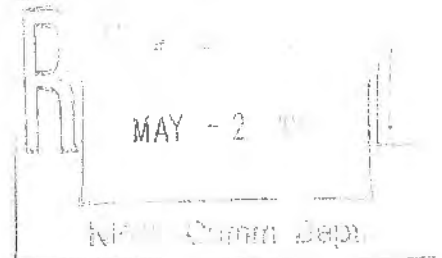

ARAPAHOE TELEPHONE COMPANY.

Exchange and Network
Services Catalog

SECTION 8

Page 18

Release 1

State of Nebraska
Notified: 05-01-2014

Effective: 07-02-2014

8. ACCESS SERVICE

(B) The customer is responsible for providing and maintaining all required customer provided equipment (CPE), which is compatible with SDSL Access Service.

(C) Access Service customer's TSP will order DSL Extended Transport from each Telephone Company designated DSL Transport Hub to its associated DSL Access Service Connection Point as described in 8.2.5 (D), following.

8.2.5 Rate Regulation

This section contains the regulations governing the rates and charges that apply for SDSL Access Service. Regulations governing the rates and charges for the Special Access Services, Frame Relay Access Service, Asynchronous Transfer Mode Cell Relay Access Service and Ethernet Transport Service provided under this tariff used in conjunction with SDSL Access Service are as specified in the National Exchange Carrier Association, Inc. Tariff FCC No. 4 in Section 7, and Sections 16.1, 16.2 and 16.3.

(A) Minimum Period

The minimum period for which SDSL Access Service is provided to a customer and for which charges are applicable is one month.

(B) Moves

A move involves a change in the physical location of one of the following:

- The Point of Termination at the SDSL Access Service customer designated premises
- The SDSL Access Service customer designated premises

The provisions for moves of SDSL Access Service are the same as those described in the National Exchange Carrier Association, Inc. Tariff FCC No. 4 in Section 7.2.3, except that an Access Order Charge will not apply to move orders for the SDSL Access Service Voice-Data option.

(C) Temporary Suspension of Service*

When an end user temporarily suspends the local exchange service that is associated with a SDSL Voice-Data option, the SDSL Voice-Data option will also be placed on temporary suspension for the same period of time, and the Telephone Company will bill the customer a temporary suspension fee, per line, per occasion, as described in the National Exchange Carrier Association, Inc. Tariff FCC No. 4 in Section 17.4.9(C). The Telephone Company will not bill the customer the monthly SDSL Voice-Data Line Charge while the SDSL Voice-Data option is placed on temporary suspension.

* The nonrecurring temporary suspension fee, as described in the National Exchange Carrier Association, Inc. Tariff FCC No. 4 in Section 17.4.9 (C), will not apply to existing customers who temporarily suspended their SDSL Voice-Data service prior to December 20, 2011.

(D) DSL Extended Transport

DSL Extended Transport is required when: 1) the Telephone Company providing SDSL Access Service locates its DSL Access Service Connection

ARAPAHOE TELEPHONE COMPANY.

Exchange and Network
Services Catalog

SECTION 8

Page 19

Release 1

State of Nebraska
Notified: 05-01-2014

Effective: 07-02-2014

8. ACCESS SERVICE

Point outside its operating territory in the operating territory of another telephone company and 2) the SDSL Access Service customer's TSP connects its customer designated premises to the DSL Access Service Connection Point using Special Access Service described in the National Exchange Carrier Association, Inc. Tariff FCC No. 4 in Section 71 preceding, or equivalent special access service provided by the other telephone company.

DSL Extended Transport is also required when: 1) the Telephone Company providing SDSL Access Service locates its DSL Access Service Connection Point outside its operating territory in the operating territory of an adjacent telephone company and 2) the SDSL Access Service customer's TSP connects its customer designated premises to the DSL Access Service Connection Point using Ethernet Transport Service described in the National Exchange Carrier Association, Inc. Tariff FCC No. 4 in Section 16.3, or equivalent Ethernet access service provided by the adjacent telephone company.

DSL Extended Transport provides the TSP with a virtual circuit path between a Telephone Company-designated DSL Transport Hub and its associated DSL Access Service Connection Point location. The Telephone Company must designate at least one DSL Transport Hub SWC location within its operating territory when it locates a DSL Access Service Connection Point outside its operating territory. The DSL Transport Hub aggregates ADSL and/or SDSL Access Services data traffic within the operating territory of the Telephone Company providing the DSL Access Service.

DSL Extended Transport is available between: 1) a DSL Transport Hub SWC and its associated DSL Access Service Connection Point SWC located within the United States when the SDSL customer's TSP connects its CDP to the DSL Access Service Connection Point using special access services, 2) a DSL Transport Hub SWC and a cross border connection point located within the United States when the Telephone Company has located its associated DSL Access Service Connection Point in Canada and the SDSL customer's TSP connects its COP to the DSL Access Service Connection Point using special access services, and 3) a DSL Transport Hub SWC and its associated DSL Access Service Connection Point SWC located in an adjacent telephone company's operating territory when the SDSL customer's TSP connects its CDP to the DSL Access Service Connection Point using Ethernet access service.

Where required, DSL Extended Transport is used to transmit ADSL and/or SDSL data traffic. DSL Extended Transport is available at a speed of 1.544 Mbps when used in conjunction with special access service and at speeds of 2 Mbps, 5 Mbps, 10 Mbps, 20 Mbps, 50 Mbps, 100 Mbps, 250 Mbps, 500 Mbps, 750 Mbps, 1 Gbps, 2.5 Gbps, 5 Gbps and 10 Gbps when used in conjunction with Ethernet access service. The TSP is responsible for determining and ordering the number of DSL Extended Transport virtual circuit paths it requires to meet its end users' data transmission needs. The TSP must place

MAY - 2 2014

ARAPAHOE TELEPHONE COMPANY.

Exchange and Network
Services Catalog

SECTION 8

Page 20

Release 1

State of Nebraska
Notified: 05-01-2014

Effective: 07-02-2014

8. ACCESS SERVICE

an order for at least one 1.544 Mbps DSL Extended Transport virtual circuit path, where required, when it places the order for Special Access Service (or equivalent special access service) to connect its customer designated premises to the DSL Access Service Connection Point. The TSP must place an order for at least one 2 Mbps DSL Extended Transport virtual circuit path, where required, when it places the order for Ethernet Transport Service (or equivalent Ethernet access service) to connect its customer designated premises to the DSL Access Service Connection Point. An Access Order Charge applies per order for the installation of DSL Extended Transport.

When the DSL Access Service Connection Point is located in Canada, DSL Extended Transport will be furnished by the Telephone Company to a cross border connection point located in the United States. DSL Extended Transport from the cross border connection point to the DSL Access Service Connection Point will be provided by the Canadian telephone company. The Telephone Company will work cooperatively with the TSP and Canadian telephone company for the provisioning of DSL Extended Transport in Canada. Rates and regulations defined in this section only apply to that portion of the service between the DSL Transport Hub and the cross border connection point.

(1) Mileage Measurement

- (a) The mileage to be used to determine the monthly charges for each DSL Extended Transport virtual circuit path is calculated using the airline distance between each DSL Transport Hub and its associated DSL Access Service Connection Point when both locations are within the United States. To determine the applicable monthly charges, first compute the mileage using the V&H coordinates method, as described in the NATIONAL EXCHANGE CARRIER ASSOCIATION, INC. TARIFF F.C.C. No.4. When the calculation results in a fraction of a mile, always round up to the next whole mile before determining the total mileage and applying the rates. Once the total mileage for each path is determined, multiply the number of miles times the DSL Extended Transport per mile rates specified in the National Exchange Carrier Association, Inc. Tariff FCC No. 4 in Section 17.4.9(F).

The Telephone Company specific rate band assignment for DSL Extended Transport is specified in the DSL Extended Transport Rate Band Column in the National Exchange Carrier Association, Inc. Tariff FCC No. 4 in Section 17.6(A).

The following example is an illustrative model, only provided for the purpose of clarification. Actual charges will vary, dependent upon the effective DSL Extended Transport per mile rates specified in the National Exchange Carrier Association, Inc. Tariff FCC No. 4 in Section 17.4.9(F), following.

Example:

- TSP orders two 1.544 Mbps DSL Extended Transport paths between a DSL Transport Hub SWC and the

ARAPAHOE TELEPHONE COMPANY.

Exchange and Network
Services Catalog

SECTION 8

Page 21

Release 1

State of Nebraska
Notified: 05-01-2014

Effective: 07-02-2014

8. ACCESS SERVICE

associated DSL Access Service Connection Point SWC. Both SWCs are located within the United States.

- Total mileage between the SWCs is calculated at 28.4 miles.

Monthly charges for DSL Extended Transport are determined as follows:

- Telephone Company specific rate band assignment for DSL Extended Transport is Rate Band 1.
- Fractional mileage rounded up to the next whole mile equals 29 miles.
- First 25 miles x \$0.00 per mile equals \$0.00 per path.
- Next four miles x \$11.00 per mile equals \$44.00 per path.
- Total mileage charges for DSL Extended Transport in this example equal \$88.00 per month (i.e., \$44.00 x two paths).

- (b) The mileage to be used to determine the monthly charges for each DSL Extended Transport virtual circuit path between a DSL Transport Hub and a cross border connection point is specified below. To calculate the monthly charges for each path, multiply the number of miles between the DSL Transport Hub and the cross border connection point times the DSL Extended Transport per mile rates specified in the National Exchange Carrier Association, Inc. Tariff FCC No. 4 in Section 17.4.9(F). The portion of the DSL Extended Transport furnished from the cross border connection point to the DSL Access Service Connection Point is the responsibility of the TSP and is not covered in this tariff as described in Section 8.2.5(D), above.

- (i) The number of miles to be used for rating DSL Extended Transport provided under this tariff between the Ketchikan Public Utilities DSL Transport Hub SWC and the Garnet Point, AK cross border connection point is 60 miles.

(E) Rate Categories

There are two types of rates and charges applicable to SDSL Access Service. These are monthly rates and nonrecurring charges.

The monthly rate for the SDSL Line Charge applies each month or fraction thereof for each SDSL Voice-Data option and SDSL Data-Only option ordered by the customer. The monthly rate for DSL Extended Transport applies each month or fraction thereof for each virtual circuit path as described in Section 8.2.5(D), preceding.

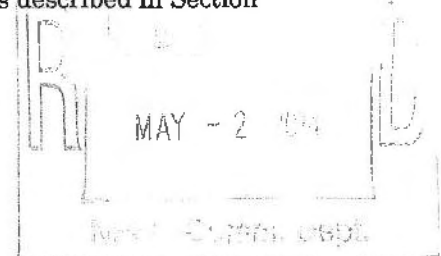

ARAPAHOE TELEPHONE COMPANY.

Exchange and Network
Services Catalog

SECTION 8

Page 22

Release 1

State of Nebraska
Notified: 05-01-2014

Effective: 07-02-2014

8. ACCESS SERVICE

A nonrecurring charge applies for each SDSL Voice-Data and SDSL Data-Only option ordered by the customer for the installation of SDSL Access Service.

The nonrecurring installation charge will be waived for each new SDSL Voice-Data 256 kbps option Access Line ordered when: 1) the customer has not previously had any ADSL or SDSL Access Service at the same location within the three months immediately prior to installing service and 2) the customer commits to retain the SDSL Voice-Data 256 kbps option Access Line for a minimum period of 6 months following installation of service.

The nonrecurring installation charge will be waived for each new SDSL Voice-Data 768 kbps option Access Line ordered when the customer commits to retain the SDSL Voice-Data 768 kbps option Access Line for a minimum period of 6 months following installation of service.

If the SDSL Voice-Data option Access Line is disconnected for any reason prior to the end of the 6-month minimum commitment period, other than for:

- an SDSL service conversion as described below, an SDSL service upgrade as described below,
- a discontinuance of service within the first 30 days of service as described below, or
- a discontinuance of service due to a fire, flood or other occurrence as described below;

The Telephone Company will bill the customer an early termination fee, as described in the National Exchange Carrier Association, Inc. Tariff FCC No. 4 in Section 17.4.9(D), for each SDSL Voice-Data option disconnected by the customer, prior to satisfying the 6-month minimum commitment period. Existing SDSL Voice-Data customers as of December 20, 2011, who are committed to a not yet concluded 12-month minimum service period but have had service for at least 6 months, are considered to have met their commitment period for waiver of the nonrecurring installation charge. Existing SDSL Voice-Data customers as of December 20, 2011, who have not yet completed 6 months of service will be covered under the new 6-month minimum commitment. The early termination fee, as described in the National Exchange Carrier Association, Inc. Tariff FCC No. 4 in Section 17.4.9 (D), will apply should service be disconnected prior to the end of the 6-month minimum commitment period.

Except as otherwise specified in Section 8.2.5(E), below, changes to an existing SDSL Access Service will be treated as a discontinuance of the existing service and an installation of a new service. Such changes include an SDSL service conversion, an SDSL service upgrade, a change of service option, a change of service level speed, or a change of TSP. A nonrecurring installation charge will apply per SDSL Access Service line for this work activity.

ARAPAHOE TELEPHONE COMPANY.

Exchange and Network
Services Catalog

SECTION 8

Page 23

Release 1

State of Nebraska
Notified: 05-01-2014

Effective: 07-02-2014

8. ACCESS SERVICE

An SDSL service conversion occurs when the customer replaces its SDSL Voice-Data 256 kbps option with an SDSL Voice-Data 768 kbps option. When a customer orders an SDSL service conversion but has not met its 6-month minimum commitment on the existing SDSL Voice-Data 256 kbps option, the Telephone Company will not bill an early termination fee for the original SDSL service, if the customer commits to a new minimum 6-month period for the newly converted SDSL Voice-Data 768 kbps option.

An SDSL service upgrade occurs when the customer replaces its SDSL Voice-Data option with any ADSL Access Service as described in Section 8.1, preceding. When an SDSL Voice-Data customer orders a service upgrade to an ADSL Access Service but has not met its 6-month minimum commitment on the existing SDSL Voice-Data option, the Telephone Company will not bill the early termination fee if the customer commits to a new minimum 6-month period for the newly ordered ADSL Access Service.

For an SDSL customer who disconnects service within the first 30 days following installation, the Telephone Company will not bill the customer the early termination fee provided: 1) the customer had not previously had SDSL Access Service at the same location within the 30 days immediately prior to installing service and 2) the customer's SDSL Access Service is disconnected by no later than the first business day following the 30th day after service was installed.

When a customer disconnects its SDSL Access Service prior to the expiration of its 6-month minimum commitment as a result of a fire, flood or other occurrence, as described in the National Exchange Carrier Association, Inc. Tariff FCC No. 4 in Section 2.4.5, the Telephone Company will not bill the early termination fee.

The following administrative changes will be made without charge to the customer:

- Change of customer premises address when the change of address is not a result of physical relocation of equipment,
- Change of the associated local exchange service line over which SDSL Voice-Data Access Service is provided when there is no physical relocation of the SDSL Access Service involved,
- Change in billing data (name, address or contact name or telephone),
- Change of billing account number,
- Change of agency authorization that requires no changes to the Telephone Company's network,
- Change in the SDSL Access Service customer's existing IP address when requested by the customer's TSP,
- Change to limit the data speed delivered over the customer's existing SDSL Access Service line when requested by the customer's TSP, Change of customer contact name or telephone number, and

MAY - 2 2014

ARAPAHOE TELEPHONE COMPANY.

Exchange and Network
Services Catalog

SECTION 8

Page 24

Release 1

State of Nebraska
Notified: 05-01-2014

Effective: 07-02-2014

8. ACCESS SERVICE

- Change of jurisdiction.

The nonrecurring installation charge will not apply to restore a SDSL Access Service that was temporarily suspended by the Telephone Company for non-payment of charges.

Rates and charges for SDSL Access Service are as set forth in the National Exchange Carrier Association, Inc. Tariff FCC No. 4 in Section 17.4.9(B), or in Section 17.4.9(H), when the customer purchases SDSL Access Service under the DSL Access Services Wholesale Pricing Plan as described in Section 8.5, following. The rates for DSL Extended Transport are as set forth in the National Exchange Carrier Association, Inc. Tariff FCC No. 4 in Section 17.4.9(F).

The Telephone Company specific rate band assignment for line charges associated with SDSL Voice-Data and SDSL Data-Only Access Service are specified in the A/SDSL Voice-Data and A/SDSL Data-Only Rate Band columns in Section 17.6(A), following.

8.3 Reserved for Future Use

ARAPAHOE TELEPHONE COMPANY.

Exchange and Network
Services Catalog

SECTION 8

Page 25

Release 1

State of Nebraska
Notified: 05-01-2014

Effective: 07-02-2014

8. ACCESS SERVICE

8.4 DSL Access Services Wholesale Pricing Plan

8.4.1 General

The telecommunications services offered under the DSL Access Services Wholesale Pricing Plan (D5L WPP) are provided at wholesale rates to the customer under the conditions listed below.

- (A) The customer purchases ADSL and/or SDSL Access Service as described in Sections 8.1 and 8.2, preceding, for the purpose of combining these telecommunications services with its own information service(s) to create a new retail service for sale to its end user customer(s).
- (B) In addition to the obligations specified in Sections 8.1.4 and 8.2.4, preceding, the customer assumes the following obligations:
 - (1) The customer will deal directly with its end user customers with respect to all matters pertaining to the service provided, including marketing, sales, ordering, installation, maintenance, trouble reporting, repair, billing and collections. The customer will not direct its end users to contact the Telephone Company for any aspect of the service the customer provides.
 - (2) The customer will submit orders for ADSL and/or SDSL Access Service to the Telephone Company in a format and manner designated by the Telephone Company.
 - (3) The customer will obtain the appropriate authorization to allow the Telephone Company to provision ADSL and/or SDSL Voice-Data Access Service over the customer's end user's existing telephone exchange service line.

When the customer purchases ADSL and/or SDSL Access Service under the DSL WPP, the rates and charges in the National Exchange Carrier Association, Inc. Tariff FCC No. 4 in Section 17.4.9(H), will apply in lieu of the rates and charges specified in the National Exchange Carrier Association, Inc. Tariff FCC No. 4 in Section 17.4.9(A), for ADSL Access Service and/or in Section 17.4.9(B), for SDSL Access Service. The DSL WPP is only available from those Telephone Companies listed in the National Exchange Carrier Association, Inc. Tariff FCC No. 4 in Section 17.6.

Services provided under the DSL WPP are available under a DSL WPP Monthly Plan at the rates and charges specified in the National Exchange Carrier Association, Inc. Tariff FCC No. 4 in Section 17.4.9(H) (1), or under a DSL WPP Term Plan described in 8.5.2, below, at the rates and charges specified in the National Exchange

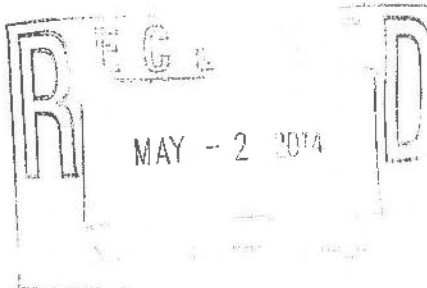

ARAPAHOE TELEPHONE COMPANY.

Exchange and Network
Services Catalog

SECTION 8

Page 26

Release 1

State of Nebraska
Notified: 05-01-2014

Effective: 07-02-2014

8. ACCESS SERVICE

Carrier Association, Inc. Tariff FCC No. 4 in Section 17.4.9(H) (2). A customer with a DSL WPP Term Plan cannot also have a DSL WPP Monthly Plan as all ADSL and/or SDSL Access Service lines within the Telephone Company's study area are included in the DSL WPP Term Plan.

The Telephone Company specific rate band assignment for services purchased under the DSL Access Services Wholesale pricing Plan is specified in the A/SDSL Rate Band column in the National Exchange Carrier Association, Inc. Tariff FCC No. 4 in Section 17.6(A).

An Access Order Charge will not apply:

- To establish a new DSL WPP Monthly Plan, DSL WPP Term Plan or DSL WPP Volume Pricing Plan.
- To change an existing DSL WPP Term Plan or DSL WPP Volume Pricing Plan.
- To convert from an existing DSL WPP Monthly Plan to a DSL WPP Term Plan and vice versa.
- To terminate an existing DSL WPP Monthly Plan, DSL WPP Term Plan, or DSL WPP Volume Pricing Plan.

A monthly charge applies for each ADSL and/or SDSL Access Service line covered under the DSL WPP. A nonrecurring charge applies for the installation of each ADSL and/or SDSL Access Service line under the DSL WPP.

The Telephone Company will convert in-service ADSL and/or SDSL Access Service lines originally purchased under the provisions specified in Sections 8.1 and 8.2, preceding, to the DSL WPP, provided the customer obtains written authorization from its end users authorizing such conversions, where necessary. Per line nonrecurring charges specified in the National Exchange Carrier Association, Inc. Tariff FCC No. 4 in Section 17.4.9(H), do not apply to the conversion of in-service ADSL and/or SDSL Access Lines to a DSL WPP.

8.4.2 DSL WPP Term Plan

(A) Description

The DSL WPP Term Plan provides the customer with reduced rates based on the length of the customer's term commitment and its selected pricing plan for all of the customer's ADSL and/or SDSL Access Service lines provided in the Telephone Company's study area. The DSL WPP Term Plan is available for term lengths of one or three years with a choice of two pricing plans. The Telephone Company will establish for the

ARAPAHOE TELEPHONE COMPANY.

Exchange and Network
Services Catalog

SECTION 8

Page 27

Release 1

State of Nebraska
Notified: 05-01-2014

Effective: 07-02-2014

8. ACCESS SERVICE

customer a single term plan commitment that will apply to all ADSL and/or SDSL Access Service lines in the Telephone Company's study area.

When the customer subscribes to a DSL WPP Term Plan, all in-service ADSL and/or SDSL Access Service lines provided out of and subsequently installed in the Telephone Company's study area will be billed the rates and charges specified in the National Exchange Carrier Association, Inc. Tariff FCC No. 4 in Section 17.4.9(H) (2), for the length of the term commitment. In addition to the applicable ADSL and/or SDSL Line Charges, the customer will be billed a recurring monthly DSL WPP Term Plan Charge per study area as specified in the National Exchange Carrier Association, Inc. Tariff FCC No. 4 in Section 17.4.9(H) (2) (a), based on its selected pricing plan. The Telephone Company specific rate band assignment for the Study Area DSL Access Service Wholesale Pricing Plan Term Plan charge is specified in the DSL WPP Term Plan Rate Band column in the National Exchange Carrier Association, Inc. Tariff FCC No. 4 in Section 17.6(A).

If the Telephone Company decreases the rates specified in the National Exchange Carrier Association, Inc. Tariff FCC No. 4 in Section 17.4.9(H) (2), during the term of a commitment period, the decreased rates will automatically be applied for the remainder of the current commitment period.

At the end of the DSL WPP Term Plan, the customer may elect to establish a new DSL wpp Term Plan commitment, convert to the rates available under the DSL WPP Monthly Plan, or discontinue service. If the customer does not make an election by the end of the DSL WPP Term Plan, the rates for all in-service ADSL and/or SDSL Access Service lines will automatically be converted to the rates available under the DSL WPP Monthly Plan specified in the National Exchange Carrier Association, Inc. Tariff FCC No. 4 in Section 17.4.9(H) (1).

A DSL WPP Term Plan is subject to payment for early termination as described in (D), below.

(B) Upgrades in DSL WPP Term Plan

A customer may terminate a DSL WPP Term Plan without the application of a termination liability charge when the customer replaces its original DSL WPP Term Plan commitment with a new DSL WPP Term Plan commitment provided the commitment period for the new DSL WPP Term

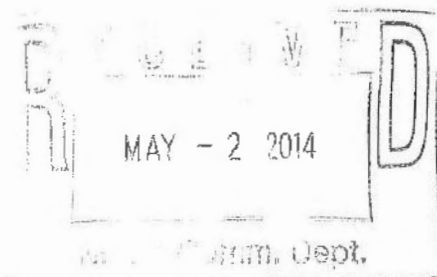

ARAPAHOE TELEPHONE COMPANY.

Exchange and Network
Services Catalog

SECTION 8

Page 28

Release 1

State of Nebraska
Notified: 05-01-2014

Effective: 07-02-2014

8. ACCESS SERVICE

Plan meets or exceeds the number of months remaining in the existing DSL WPP Term Plan commitment period.

(C) Termination without Liability

A customer may terminate a DSL WPP Term Plan commitment without the application of a termination liability charge if the Telephone Company increases the DSL WPP Term Plan rates described in the National Exchange Carrier Association, Inc. Tariff FCC No. 4 in Section 17.4.9(H) (2), during the term of the existing commitment. The customer has 90 days following such rate increase to notify the Telephone Company in writing of its intent to terminate its DSL WPP Term Plan commitment under this section; otherwise, the increased rates will apply for the remainder of the commitment period.

(D) Termination with Liability

If the customer elects to terminate its DSL WPP Term Plan prior to the end of the commitment period for any reason other than specified in (B) or (C), above, a termination liability charge will apply. If the DSL WPP Term Plan is terminated prior to the end of the commitment period, the Telephone Company will bill the customer a charge equal to the monthly DSL WPP Term Plan Charge for its selected pricing plan as specified in the National Exchange Carrier Association, Inc. Tariff FCC No. 4 in Section 17.4.9(H) (2) (a), multiplied by the number of months remaining in the commitment period. DSL WPP Monthly Plan rates as described in the National Exchange Carrier Association, Inc. Tariff FCC No. 4 in Section 17.4.9(H) (1), will apply to all in-service ADSL and/or SDSL Access Lines following the early termination of a DSL WPP Term Plan.

(E) DSL Volume Pricing Plan

The DSL Volume Pricing Plan (DSL VPP) is an optional pricing plan that provides the DSL WPP Term Plan customer with a discount applied against the monthly ADSL and/or SDSL Line Charges for all of its in-service lines in the Telephone Company's study area. In order to subscribe to and retain the DSL VPP, the customer must have a DSL WPP Term Plan commitment with the Telephone Company. The amount of the DSL VPP discount applied is based on the level of the monthly volume commitment selected by the DSL WPP Term Plan customer. The DSL VPP discount does not apply to

ARAPAHOE TELEPHONE COMPANY.

Exchange and Network
Services Catalog

SECTION 8

Page 29

Release 1

State of Nebraska
Notified: 05-01-2014

Effective: 07-02-2014

8. ACCESS SERVICE

WPP Term Plan Line Charges specified in the National Exchange Carrier Association, Inc. Tariff FCC No. 4 in Section 17.4.9 (H) (2) (b).

The customer will select its monthly volume commitment level based on its projected number of monthly in-service ADSL and SDSL Access Service lines within the Telephone Company's study area.

In-service ADSL and SDSL Access Service lines billed under the DSL WPP Monthly Plan are not eligible for the DSL VPP discount.

Available DSL VPP commitment levels and associated discounts are specified in the National Exchange Carrier Association, Inc. Tariff FCC No. 4 in Section 17.4.9(H) (2) (c).

The customer may order the DSL VPP at the same time it establishes a DSL WPP Term Plan commitment or at any time prior to the expiration of the existing DSL WPP Term Plan. The DSL VPP monthly commitment and discount applies for the balance of the DSL WPP Term Plan commitment period and ends when: (1) the DSL WPP Term Plan is terminated by the customer, (2) the DSL VPP is terminated by the customer, or (3) the DSL WPP Term Plan commitment is satisfied.

Each month on the bill date, the Telephone Company will determine if the DSL WPP Term Plan customer achieved its monthly volume commitment level of in-service ADSL and SDSL Access Service lines. In any month in which the monthly volume commitment was not met, the Telephone Company will bill the customer a DSL VPP shortfall charge of \$10.00 per line for each line below its volume commitment level. The following example illustrates the application of the shortfall charge for a DSL WPP Term plan customer that selected a monthly volume commitment level of 2,500 lines. If on the bill date, the customer had achieved only a total of 2,250 in-service lines, the Telephone Company would assess a shortfall charge of \$2,500.00 (250 lines x \$10.00 per line). The shortfall charge would be in addition to the applicable discounted billing for the 2,250 in-service lines.

Upon providing thirty (30) days written notice to the Telephone Company, a customer with an existing DSL VPP will be permitted to increase the existing volume commitment when it establishes a new higher volume commitment level. The DSL VPP discount associated with the higher level of

MAY - 2 2014

COMM. DEPT.

ARAPAHOE TELEPHONE COMPANY.

Exchange and Network
Services Catalog

SECTION 8

Page 30

Release 1

State of Nebraska
Notified: 05-01-2014

Effective: 07-02-2014

8. ACCESS SERVICE

commitment will apply on a prospective basis for the balance of the DSL WPP Term Plan commitment period. Upon providing thirty (30) days written notice to the Telephone Company, a customer with an existing DSL VPP will be permitted to terminate its existing volume commitment on a prospective basis as described herein. When the customer elects to terminate its existing DSL VPP for any reason, it will be prohibited from establishing a new DSL VPP commitment with the Telephone Company within the ninety (90) days following such termination. During this 90-day period, the customer will not be eligible for any DSL VPP discounts. Downgrades from a higher volume commitment level to a lower volume commitment level are treated as terminations subject to the provisions in this paragraph.

ARAPAHOE TELEPHONE COMPANY

Exchange and Network
Services Catalog

SECTION 9

Index Page 1

Release 1

State of Nebraska

Notified: 12-19-96

Effective: 1-2-97

9. CENTRAL OFFICE SERVICES

SUBJECT	PAGE
Emergency Reporting Service	1
Universal Emergency Number Service - 911	1

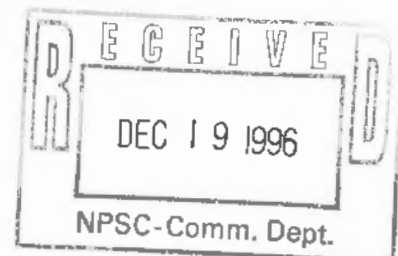

ARAPAHOE TELEPHONE COMPANY

Exchange and Network
Services Catalog

SECTION 9

Page 1

Release 1

Effective: 1-2-97

State of Nebraska
Notified: 12-19-96

9. CENTRAL OFFICE SERVICES

9.1 EMERGENCY REPORTING SERVICE

9.1.1 UNIVERSAL EMERGENCY NUMBER SERVICE - 911

A. General

1. Definitions

Automatic Number Identification (ANI)

A feature by which the calling party's ANI telephone number is forwarded to the 911 Control Office and to the PSAP's Display and Transfer Units.

Automatic Number Identification (ANI) Trunk Unit

Central office equipment which provides the capability of combining the 911 voice call and the ANI onto the same 911 exchange line.

Dedicated Direct Facilities

Channels between the central office from which the emergency call originates (originating central office) and the PSAP which do not utilize the switching equipment of intermediate central offices and which require dedicated physical pairs of wires.

Emergency Service Number (ESN)

When the Selective Routing feature is provided, the customer is responsible for identifying primary and secondary PSAP locations as well as unique combinations of police, fire and ambulance or any other appropriate agencies responsible for providing emergency service in the 911 serving area. An ESN will be provided for each unique combination by the Company. The customer will associate these ESNs with street address ranges or other mutually agreed upon routing criteria in the 911 serving area. The ESNs will be carried in the Data Management System (DMS) to permit routing of 911 calls to the primary and secondary PSAPs responsible for handling of calls from each telephone in the 911 serving area.

End Office

A central office in the 911 System which receives originating 911 calls and routes them to a given PSAP.

Master Street Address Guide (MSAG)

The document or computer file that lists the standard street names, address ranges, and routing codes used in the Data Management System of a 911 system equipped with Selective Routing and/or Automatic Location Identification (ALI).

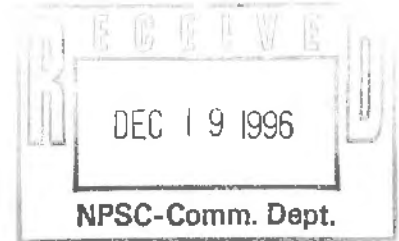

NOTICE

THE INFORMATION CONTAINED IN THIS DOCUMENT IS SUBJECT TO CHANGE.

ARAPAHOE TELEPHONE COMPANY

Exchange and Network
Services Catalog

SECTION 9

Page 2

Release 1

State of Nebraska

Notified: 12-19-96

Effective: 1-2-97

9. CENTRAL OFFICE SERVICES

NXX

The first three numbers or digits of the customer's seven-digit telephone number.

P.01 Grade of Service

Trunk facility provisioning to ensure that during the average busy hour, no more than 1% of calls into the 911 system will encounter a busy condition.

Public Safety Answering Point (PSAP)

An answering location for 911 calls originating in a given area. A PSAP may be designated as Primary or Secondary, which refers to the order in which calls are directed for answering. Primary PSAPs respond first; Secondary PSAPs receive calls on a transfer basis only and generally serve as a centralized answering location for a particular type of emergency call. PSAPs are staffed by employees of service agencies each as police, fire or emergency medical or by employees of a common bureau serving a group of such entities.

Serving Central Office

The central office from which a PSAP, either primary or secondary, is served.

Subscriber Records

Information consisting of subscribers' names, service addresses, and telephone numbers to a 911 customer for the sole purpose of building and maintaining a data base used in providing 911 service to a specific geographical area. The Subscriber Records information does not include an MSAG nor does it include ESN information. ESN information would be provided on an individual case basis.

Universal Emergency Number Service

A telephone exchange communication service for receiving telephone calls placed by persons in need of assistance who dial the number 911. Such calls are answered at PSAPs established and operated by the customer.

Universal Emergency Number Service Customer

A municipality or other state or local governmental unit or an authorized agent of one or more municipalities or other state or local governmental units to whom authority has been lawfully delegated within a defined geographic area to respond to public emergency telephone calls, at the minimum for police and fire service.

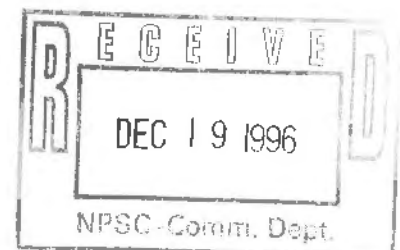

NOTICE

THE INFORMATION CONTAINED IN THIS DOCUMENT IS SUBJECT TO CHANGE.

ARAPAHOE TELEPHONE COMPANY

Exchange and Network
Services Catalog

SECTION 9

Page 3

Release 1

Effective: 1-2-97

State of Nebraska

Notified: 12-19-96

9. CENTRAL OFFICE SERVICES

2. Terms and Conditions

- a. The 911 customer may be a municipality or other state or local government unit, or an authorized agent of one or more municipalities or other state or local governmental units, to whom authority has been lawfully delegated. The customer will have public safety responsibility to respond to police, fire or other emergency services' telephone calls within the telephone central office areas where 911 Service is provided.
- b. 911 Service is provided solely for the benefit of the customer operating the PSAP. The provision of 911 Service by the Company shall not be interpreted, construed, or regarded, either expressly or implied, as being for the benefit of or creating any Company obligation toward any third person or legal entity other than the customer.
- c. The Company does not undertake to answer and forward 911 calls, but provides facilities to enable the customer's personnel to respond to such calls (from the customer's premises).
- d. Any CPE used in conjunction with 911 Service shall be configured so that it is unable to extract any information other than the information relating to a number identified as the source of an in-progress 911 call through use of the optional ANI feature.
- e. Company subscriber names, addresses and telephone numbers provided to a 911 system are private data and may be used only for identifying the location or identity, or both, of a person calling a 911 PSAP. Company subscriber information may not be used or disclosed by 911 system agencies, their agents, or their employees for any other purpose except under a court order.
- f. The calling party forfeits the privacy afforded by nonlisted and nonpublished service to the extent that the telephone number, address and name associated with the originating station location are furnished to the PSAP during an emergency call to 911, when the customer has subscribed to the optional ANI feature.
- g. Temporary suspension of service at reduced rates is not provided for any part of 911 Service.
- h. This service is limited to the use of telephone number 911 as the universal emergency telephone number. Only one 911 Service will be provided within any governmental agency's locality.
- i. The Company will not provide 911 Service to less than an entire central office and will only provide one set of 911 trunking out of that central office.



NOTICE

THE INFORMATION CONTAINED IN THIS DOCUMENT IS SUBJECT TO CHANGE.

ARAPAHOE TELEPHONE COMPANY

Exchange and Network
Services Catalog

SECTION 9

Page 4

Release 1

Effective: 1-2-97

State of Nebraska

Notified: 12-19-96

9. CENTRAL OFFICE SERVICES

- j. Application for 911 Service must be executed in writing by each participating local governmental authority or their duly appointed agent. If application for service is made by an agent, satisfactory evidence of the appointment must be provided in writing to the Company. At least one local law enforcement agency must be included among the participating agencies in any 911 Service offering.
- k. 911 Service is furnished to the customer for the sole purpose of receiving reports of emergencies from the public. The 911 emergency telephone number is not intended as a replacement for the telephone service of the various public safety agencies which participate in the use of this number. The public safety agencies must subscribe to other exchange telephone service as provided in other sections of this Catalog.
- l. 911 exchange lines are classified as Business service and are arranged for one-way incoming service to the appropriate PSAP. Outgoing calls can only be made on non-911 facilities.
- m. The rates charged for E911 Service do not contemplate the inspection or constant monitoring of facilities to discover errors, defects and malfunctions in the service, nor does the Company undertake such responsibility. The customer shall make such operation test as, in the judgment of the customer, are required to determine whether the system is functioning properly for its use. The customer shall promptly notify the Company in the event the system is not functioning properly.
- n. The Company's entire liability to any person for interruption or failures of 911 Service shall be limited to the terms set forth in this section and Section 2.

The Company's liability for any loss or damage arising from errors, interruptions, defects, failures or malfunctions of this service or any part thereof, whether caused by the negligence of the Company or otherwise, shall not exceed the greater of \$50.00 or an amount equivalent to the pro rata charges for the service affected during the period of time that the service was fully or partially inoperative. These limited damages shall be in addition to any credit which may be given for an out-of-service condition as specified in Section 2.

- o. Each customer agrees to release, indemnify, defend and hold harmless the Company from any and all loss, claims, demands, damages, expenses, suits or other action, or any liability whatsoever including, but not limited to, costs and attorney's fees, whether suffered, made, instituted or asserted by the customer or by any other party or person, for personal injury to or death of any person or persons, or for any loss, damage or destruction of any property, whether owned by the customer or others, arising out of or resulting from customer's acts or omissions.

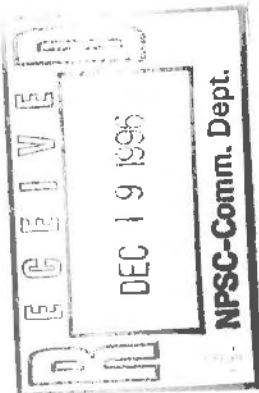

NOTICE

THE INFORMATION CONTAINED IN THIS DOCUMENT IS SUBJECT TO CHANGE.

ARAPAHOE TELEPHONE COMPANY

Exchange and Network
Services Catalog

SECTION 9

Page 5

Release 1

State of Nebraska
Notified: 12-19-96

Effective: 1-2-97

9. CENTRAL OFFICE SERVICES

- p. The customer also agrees to release, indemnify and hold harmless the Company for any infringement or invasion of the right of privacy of any person or persons, caused or claimed to have been caused, directly or indirectly, by the installation, operation, failure to operate, maintenance, removal, presence, condition, occasion or use of 911 Service and the equipment associated therewith, or by any services furnished by the Company in connection therewith, including, but not limited to, the identification of the telephone number used by persons accessing 911 Service, and which arises out of the negligence or other wrongful act of the customers, its user, agencies or municipalities, or the employees or agents of any one of them.
- q. Because the Company serving boundaries and political subdivision boundaries may not coincide, it is the obligation of the customer to make arrangements to handle all 911 calls that originate from telephones served by central offices in the local service area whether or not the calling telephone is situated on property within the geographical boundaries of the customer's public safety jurisdiction.
- r. No charge applies to the calling party for calls placed to the 911 emergency number.
- s. In addition to the recurring rates, nonrecurring charges appropriate for connection, move or change will apply to 911 transport features.
- t. It is the customer's responsibility to insure that CPE selected to operate 911 system features is compatible with service furnished by the Company.
- u. The customer purchasing the ANI feature is also required to purchase, install and maintain CPE ANI Display Equipment compatible to the Company's network.



B. Basic Universal Emergency Number Service (B911)

1. Description

B911 Emergency Service provides call delivery to the Public Safety Answering Point (PSAP). This service is designed for direct trunking from the end office to the PSAP.

2. Terms and Conditions

- a. The customer selecting features is required to purchase B911 transport.
- b. Regardless of whether the originating central office is in an exchange or zone which is inside or outside of the local calling area of the exchange or zone in which the PSAP is located, B911 exchange lines will be provided for incoming B911 calls via dedicated direct facilities.
- c. It is the customer's responsibility to insure that premises equipment selected that has the Store and Forward feature be compatible with the service furnished by the Company.

NOTICE

THE INFORMATION CONTAINED IN THIS DOCUMENT IS SUBJECT TO CHANGE.

ARAPAHOE TELEPHONE COMPANY

Exchange and Network
Services Catalog

SECTION 9

Page 6

Release 1

State of Nebraska
Notified: 12-19-96

Effective: 1-2-97

9. CENTRAL OFFICE SERVICES

- d. In cases where interLATA circuits are required, fixed and per mile transport mileage charges in 4., following, will apply for mileage from the originating central office to the LATA tandem as well as from the LATA tandem to the PSAP serving central office. All mileage is based on V & H coordinates. In addition, a flat rate to cross the LATA boundary applies.

The Company will select an interLATA carrier if the customer chooses to buy interLATA transport from the Company. If not, it will be the customer's responsibility to negotiate service with a carrier of choice. The Company will deliver B911 calls to the Company LATA access tandem for the carrier to pick up.

- e. The customer may take advantage of network consolidation in a Host/Remote type switch configuration by using the Host as the originating central office. All mileage under this configuration would be calculated from the Host.
- f. Each participating local governmental authority must furnish the Company written agreement to the following terms and conditions:
- (1) The PSAP will be provided and staffed on a 24-hour coverage basis.
 - (2) The customer accepts responsibility for serving the entire geographic area served by the central office through which 911 calls are routed to the PSAP, even though such central office serving areas and community boundaries may not coincide.
 - (3) The customer must subscribe to a minimum of two B911 exchange lines to maintain a P.01 grade of service.
 - (4) The customer accepts responsibility for dispatching, or having others dispatch, police, fire, ambulance or other emergency services as required, to the extent such services are reasonably available.
 - (5) The customer must subscribe to additional local exchange service, at the PSAP location, for administrative purposes, for placing of outgoing calls and for receiving other emergency calls, including any which might be relayed by Company operators.
- g. Tie lines, private lines, extension service lines and other such channels connecting a PSAP to various agencies such as police, fire or ambulance service are provided at established rates for such channels and facilities, as specified elsewhere.
- h. One Channel Connection and one Channel Transmission Parameter are required for each B911 Transport line.

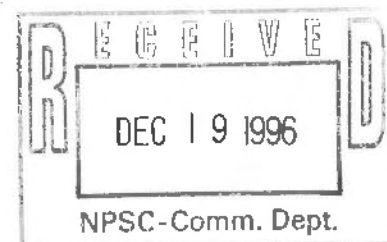

NOTICE

THE INFORMATION CONTAINED IN THIS DOCUMENT IS SUBJECT TO CHANGE.

ARAPAHOE TELEPHONE COMPANY

Exchange and Network
Services Catalog

SECTION 9

Page 7

Release 1

State of Nebraska

Notified: 12-19-96

Effective: 1-2-97

9. CENTRAL OFFICE SERVICES

3. B911 Features

Automatic Number Identification (ANI)

A feature by which the calling party's telephone number is forwarded and displayed to the PSAP.

Called Party Hold

Enables the PSAP attendant to retain control of the connection regardless of the switchhook status of the calling party.

Emergency Ringback

Allows the PSAP attendant to ring a calling party who has gone on-hook after the B911 call has been answered by the attendant.

Forced Connect

Allows the PSAP attendant to release a connected call even though the calling party has not hung up. This prevents blockage of the incoming 911 exchange lines serving the PSAP.

Idle Tone Application

Allows the PSAP attendant to distinguish between calls abandoned before they are answered and instances in which the calling party is unable to speak for some reason. If this call is abandoned, a distinct tone is heard. If the caller is still on the line but unable to speak, no tone is heard.

Switchhook Status

Indicates to the PSAP attendant by means of audible and visual signals that a held 911 call has hung up (gone to an on-hook status). This feature is limited to B911 calls provided via metallic facilities.

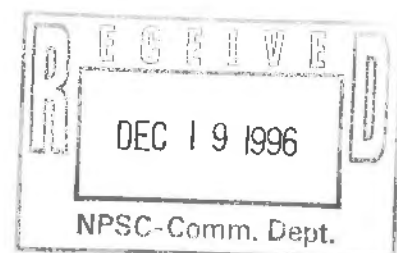

NOTICE

THE INFORMATION CONTAINED IN THIS DOCUMENT IS SUBJECT TO CHANGE.

ARAPAHOE TELEPHONE COMPANY

Exchange and Network
Services Catalog

SECTION 9

Page 8

Release 1

Effective: 1-2-97

State of Nebraska

Notified: 12-19-96

9. CENTRAL OFFICE SERVICES

4. Rates and Charges

	USOC	NONRECURRING CHARGE	MONTHLY RATE
a. B911 Transport			
(1) Channel Connection[1,2]			
• 2 wire, per channel	XCD2X	-	\$ 6.95
- First Network Channel installed	SCH	\$ 258.30	-
- Additional Network Channel(s) installed, each	SCHAX	77.32	-
• 4 wire, per channel	XCD4X	-	13.85
- First Network Channel installed	SCH	258.30	-
- Additional Network Channel(s) installed, each	SCHAX	77.32	-
(2) Channel Transmission Parameter[1]			
• Voice Grade (VG) 32 with Loop Start Signalling	CE9DX	84.52	11.00
• Data	CE9LX	95.45	14.10
• Voice Grade (VG) 33 reverse battery signalling	CE91X	88.61	14.05

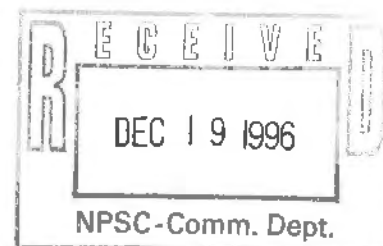

[1] Rotary Line service rate is not included and will be applied as an additional rate. See 5.2.5.

[2] Mileage charges also apply as specified in (4), following.

NOTICE

THE INFORMATION CONTAINED IN THIS DOCUMENT IS SUBJECT TO CHANGE.

ARAPAHOE TELEPHONE COMPANY

Exchange and Network
Services Catalog

SECTION 9

Page 9

Release 1

Effective: 1-2-97

State of Nebraska

Notified: 12-19-96

9. CENTRAL OFFICE SERVICES

	USOC	NONRECURRING CHARGE	MONTHLY RATE
(3) 911 Provisioning [1]	91L		
(4) Transport Mileage, per Mileage Band			
Mileage Bands			
• Over 0 to 8			
- Fixed	XU9E3	\$ 44.39	\$ 28.75
- Per mile	XE9EC	-	0.25
• Over 8 to 25			
- Fixed	XU9E4	44.39	28.75
- Per mile	XE9ED	-	0.25
• Over 25 to 50			
- Fixed	XU9E5	44.39	28.75
- Per mile	XE9EE	-	0.25
• Over 50			
- Fixed	XU9E6	44.39	28.75
- Per mile	XE9EF	-	0.25
(5) InterLATA Transport			
Per Circuit[2]	XE8QX	35.00	68.75

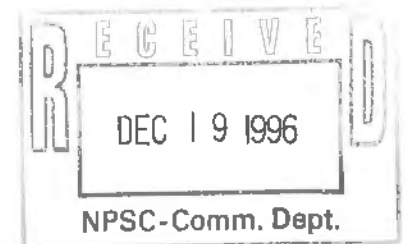

[1] USOC 91L has no rate and charge and is used for internal tracking purposes only.

[2] These charges are in addition to all other mileage and nonrecurring charges.

NOTICE

THE INFORMATION CONTAINED IN THIS DOCUMENT IS SUBJECT TO CHANGE.

ARAPAHOE TELEPHONE COMPANY

Exchange and Network
Services Catalog

SECTION 9

Page 10

Release 1

State of Nebraska
Notified: 12-19-96

Effective: 1-2-97

9. CENTRAL OFFICE SERVICES

b. B911 Features

Features will be provided at the following rates and charges and are in addition to applicable rates and charges for B911 transport and other services or equipment with which they are associated:

	USOC	NONRECURRING CHARGE	MONTHLY RATE
• 911 Code Recognition[1]	98H	ICB	
• ANI, per B911 exchange line equipped	D98	\$ 758.75	\$ 10.10
• B911 with feature package and ANI	9DJ	261.40	176.70
B911 Features	B92	234.00	10.55

C. Enhanced Universal Emergency Number Service (E911)

1. Description

Enhanced Universal Emergency Number Service (E911) is a telephone exchange communication service whereby one or more PSAPs, designated by the customer, may receive telephone calls dialed to the telephone number 911. E911 Service includes lines and equipment within the Company's Exchange Territory which can be connected to lines and equipment in Independent Company Exchange Territory to permit answering, transferring and dispatching of public emergency telephone 911 calls originated by persons within the serving area. E911 Service provides for Selective Routing, Automatic Number Identification, and Automatic Location Identification features.

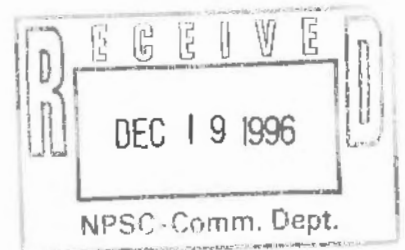

[1] Rate and charges are in addition to rate and charges for 911 transport.

NOTICE

THE INFORMATION CONTAINED IN THIS DOCUMENT IS SUBJECT TO CHANGE.

ARAPAHOE TELEPHONE COMPANY

Exchange and Network
Services Catalog

SECTION 9

Page 11

Release 1

State of Nebraska
Notified: 12-19-96

Effective: 1-2-97

9. CENTRAL OFFICE SERVICES

2. Definitions

Additional E911 Exchange Line

Additional terminating line at a PSAP that may be ordered by the customer as an optional feature.

Alternate Routing (AR)

A feature provided to allow E911 calls to be routed to a designated alternate location if all E911 exchange lines to the primary PSAP are busy, or the primary PSAP closes down for a period (night service). This is a standard feature of E911 Service.

Automatic Location Identification (ALI)

A feature by which the name (business accounts only) and address associated with the calling party's telephone number (identified by ANI as defined below) is forwarded to the PSAP for display. Additional telephones with the same number as the calling party's (secondary locations, off premises, etc.), will be identified with the address of the telephone number at the main location.

Data Management System (DMS)

A system of manual procedures and computer programs used to create, store and update the data required to provide the Selective Routing (SR) and ALI features.

Default Routing (DR)

A feature activated when an incoming E911 call cannot be selectively routed due to an ANI failure, garbled digits or other causes. Such incoming calls are routed from the E911 Control Office to a default PSAP. Each incoming E911 facility group to the Control Office is assigned to a designated default PSAP. This is a standard feature of E911 Service.

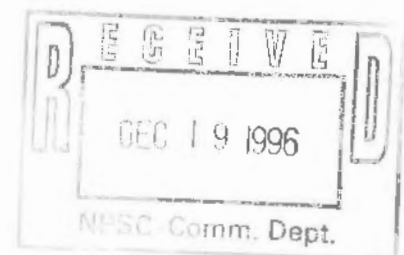

NOTICE

THE INFORMATION CONTAINED IN THIS DOCUMENT IS SUBJECT TO CHANGE.

ARAPAHOE TELEPHONE COMPANY

Exchange and Network
Services Catalog

SECTION 9

Page 12

Release 1

State of Nebraska

Notified: 12-19-96

Effective: 1-2-97

9. CENTRAL OFFICE SERVICES

Display and Transfer Unit

A selector console and associated common equipment for displaying ANI numbers at the PSAP attendant position and used by the attendant to activate Fixed and/or Selective Transfer functions. It is the customer's responsibility to ensure the CPE selected to operate this feature is compatible with the service furnished by the Company.

E911 Control Office

The office providing tandem switching capability for E911 calls. It controls switching of ANI information to the PSAP and also provides the SR feature, standard ESS Speed Calling features, call transfer capability and certain maintenance functions for each PSAP.

E911 Service Area

The geographic area in which the customer will respond to all E911 calls and dispatch appropriate emergency assistance.

E911 Transport

Utilization of dedicated point-to-point facilities between an End Office and an E911 Control Office, a Control Office and a PSAP Serving Central Office, and/or a PSAP Serving Central Office and a Node to transmit a telephone number (ANI Transport), a name and address (ALI Transport), or routing information (Selective Routing Transport) associated with a 911 call.

Fixed Transfer

A feature which enables a PSAP attendant to transfer incoming E911 calls to secondary PSAPs by use of a single button on the Display and Transfer Unit.

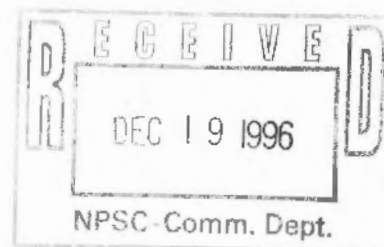

NOTICE

THE INFORMATION CONTAINED IN THIS DOCUMENT IS SUBJECT TO CHANGE.

ARAPAHOE TELEPHONE COMPANY

Exchange and Network
Services Catalog

SECTION 9

Page 13

Release 1

Effective: 1-2-97

State of Nebraska
Notified: 12-19-96

9. CENTRAL OFFICE SERVICES

Forced Disconnect

A function of the E911 central office trunk circuit which enables the PSAP attendant to release a connection even though the calling party has not hung up. This feature prevents the jamming of the E911 exchange lines and is a standard feature of E911 Service.

Manual Transfer

A feature that enables the PSAP attendant to transfer an incoming call by depressing the switchhook of the associated telephone or the "add" button on the Display and Transfer Unit and dialing either a 7-digit or 10-digit telephone number or a 2-digit Speed Calling Code. Manual Transfer is associated with the E911 trunk unit and is a standard feature of E911 Service.

Selective Routing (SR)

A feature that routes an E911 call from a central office to the designated primary PSAP based upon the identified number of the calling party.

Selective Transfer

A feature providing persons at the PSAP the ability to transfer an incoming call to another agency by depressing a single button labeled with the type of agency, e.g., "Fire," on the Display and Transfer Unit. This type of transfer is only available when the SR feature is provided. It is the customer's responsibility to ensure the CPE selected to operate this feature is compatible with the service furnished by the Company.

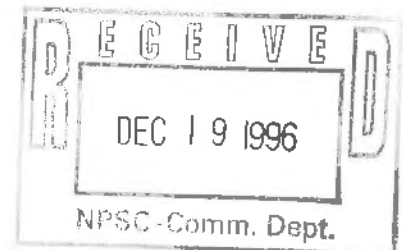

NOTICE

THE INFORMATION CONTAINED IN THIS DOCUMENT IS SUBJECT TO CHANGE.

ARAPAHOE TELEPHONE COMPANY

Exchange and Network
Services Catalog

SECTION 9

Page 14

Release 1

State of Nebraska

Notified: 12-19-96

Effective: 1-2-97

9. CENTRAL OFFICE SERVICES

3. Terms and Conditions

- a. Application for E911 Service must be executed in writing by each customer. If application for service is made by an agent, satisfactory proof of appointment of the agent by the customer, must be provided in writing to the Company. At least one local law enforcement agency must be included among the participating agencies in any 911 offering.
- b. The customer is required to furnish the Company its agreement to the following terms and conditions:
 - That all E911 calls will be answered on a 24-hour day, seven-day week basis.
 - That the customer has responsibility for dispatching the appropriate emergency service vehicles within the E911 service area, or will undertake to transfer all E911 calls received to the governmental agency with responsibility for dispatching such services, to the extent that such services are reasonably available.
 - That the customer will develop an appropriate method for responding to calls for nonparticipating agencies which may be directed to the E911 PSAP by calling parties.
 - That the customer will subscribe to local exchange service at the PSAP location for administrative purposes, for placing outgoing calls, and for receiving other calls.
 - That the customer will provide CPE with a capacity adequate to handle the number of incoming E911 lines recommended by the Company. It is the customer's responsibility to ensure the CPE selected to operate this feature is compatible with the service furnished by the Company.

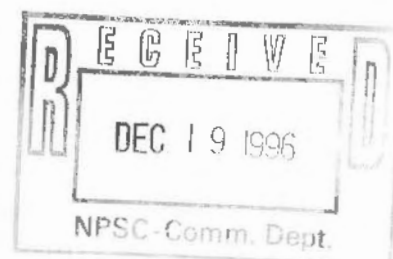

NOTICE

THE INFORMATION CONTAINED IN THIS DOCUMENT IS SUBJECT TO CHANGE.

ARAPAHOE TELEPHONE COMPANY

Exchange and Network
Services Catalog

SECTION 9

Page 15

Release 1

State of Nebraska
Notified: 12-19-96

Effective: 1-2-97

9. CENTRAL OFFICE SERVICES

- c. Default Routing and central office identification will be provided in lieu of Selective Routing and ANI Display for E911 systems served from central offices not equipped to transmit ANI. Central offices that are not currently equipped to transmit ANI will not be modified to provide ANI just for E911 Service.
- d. Central office identification is provided in lieu of ANI/ALI on calls placed from rural lines.
- e. E911 information consisting of the names, addresses and telephone numbers of telephone customers whose listings are not published in directories or listed in Directory Assistance offices is confidential. Information will be provided on a call-by-call basis only for the purpose of responding to 911 emergency calls.
- f. When the Selective Routing feature is provided, the customer is responsible for identifying primary and secondary PSAP locations as well as the unique combinations of police, fire and ambulance or any other appropriate agencies responsible for providing emergency service in the E911 serving area. An Emergency Service Number (ESN) will be provided for each unique combination by the Company. The customer will associate these with street address ranges or other mutually agreed upon routing criteria in the E911 serving area. These ESNs will be carried in the Data Management System (DMS) to permit routing of 911 calls to the primary and secondary PSAPs responsible for handling of calls from each telephone in the E911 serving area. The following terms define the customer's responsibility in providing this information:
 - Initial and subsequent ESN assignments by street name, address range and area or other mutually agreed upon routing criteria shall be furnished by the customer to the Company prior to the effective date of service.
 - After establishment of service, it is the customer's responsibility to continue to verify the accuracy of the routing information contained in the master address files and to advise the Company of any changes in street names, establishment of new streets, changes in address numbers used on existing streets, closing and abandonment of streets, changes in police, fire, ambulance or other appropriate agencies' jurisdiction over any address, annexations and other changes in municipal and county boundaries, incorporation of new cities or of any other matter that will affect the routing of E911 calls to the proper PSAP.
 - The Company will provide to the customer on request a complete written copy of the master address file to permit the customer to verify accuracy of the police, fire, and ambulance PSAP routing designations.
 - Changes, deletions and additions which the customer desires to have made in the master address file should be submitted on an "as occurred" basis.



NOTICE

THE INFORMATION CONTAINED IN THIS DOCUMENT IS SUBJECT TO CHANGE.

ARAPAHOE TELEPHONE COMPANY

Exchange and Network
Services Catalog

SECTION 9

Page 16

Release 1

State of Nebraska

Notified: 12-19-96

Effective: 1-2-97

9. CENTRAL OFFICE SERVICES

- The Company will furnish a written copy to the customer for verification showing each change, deletion and addition to the master address file.
- g. Where facilities permit, the customer can request diversification and redundancy of any or all inter-office and/or local facility routes. Additional charges for such service utilizing the facilities, or the construction and provisioning thereof, will be the responsibility of the customer and will be assessed on an individual case basis (ICB).

4. E911 Features

- a. E911 Service is available in five Service Feature Offerings:

Automatic Number Identification

Charges are based on the total number of main and equivalent main telephones served by the local switching offices equipped for ANI only.

Selective Routing

Not available as a stand-alone feature. To be developed as the demand for Selective Routing is required.

Automatic Number Identification and Selective Routing

Charges are based on the total number of main and equivalent main telephones to which both ANI and SR apply.

Automatic Number Identification and Automatic Location Identification

Charges are based on the total number of main and equivalent main telephones served by the local switching office equipped for ANI and ALI but not SR.

Automatic Number Identification, Automatic Location Identification and Selective Routing

Charges are based upon the total number of main and equivalent main telephones to which ANI, ALI and SR apply.[1]

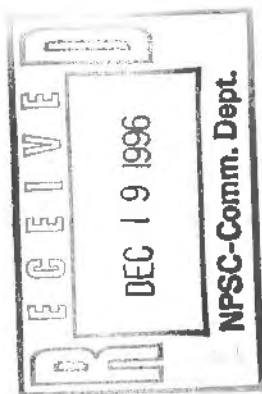

[1] When SR is introduced, different features may be applied to the SR subsets without being applied to the total main and equivalent main telephones served by the local switching office. Thus, where two jurisdictions are served by a local switching office, each jurisdiction may select a different feature combination as long as SR is one of the features.

NOTICE

THE INFORMATION CONTAINED IN THIS DOCUMENT IS SUBJECT TO CHANGE.

ARAPAHOE TELEPHONE COMPANY

Exchange and Network
Services Catalog

SECTION 9

Page 17

Release 1

State of Nebraska

Notified: 12-19-96

Effective: 1-2-97

9. CENTRAL OFFICE SERVICES

b. The following standard features are included with each of the service offerings:

- Forced Disconnect
- Default Routing
- Alternate Routing (Night Service)
- Speed Calling
- Central Office Transfer Arrangements

5. E911 Transport

- a. All E911 facilities will be engineered, installed, and maintained by the Company at sufficient levels to provide a minimum of P.01 Grade of Service. In all situations, a minimum of two circuits will be provided to connect each End Office in the E911 System to the E911 Control Office and/or to the PSAP Serving Central Office.
- b. Secondary PSAPs that are not equipped to display ANI information on CPE will receive calls on a transfer basis over the exchange network or the customer may subscribe for an additional E911 Exchange Line.

6. Rates and Charges

a. General

- Travel charges apply in addition to rates and charges specified following.
- Charges for messages transferred over exchange facilities from a PSAP are billed accordingly to rates applicable from the central office serving the PSAP initiating the transfer to the point of termination of the transfer.

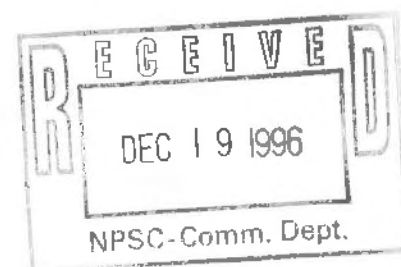

NOTICE

THE INFORMATION CONTAINED IN THIS DOCUMENT IS SUBJECT TO CHANGE.

ARAPAHOE TELEPHONE COMPANY

Exchange and Network
Services Catalog

SECTION 9

Page 18

Release 1

Effective: 1-2-97

State of Nebraska

Notified: 12-19-96

9. CENTRAL OFFICE SERVICES

	USOC	NONRECURRING CHARGE[1]	MONTHLY RATE[1]
b. Service Features			
(1) Automatic Number Identification, per 1,000 main stations served[2]	E8X	\$ 884.81	\$ 38.53
(2) Selective Routing, per 1,000 main stations served[2]	E8R	[3]	[3]
(3) Combined Automatic Number Identification and Selective Routing, per 1,000 main stations served[2]	E8T	\$1,409.81	\$68.53

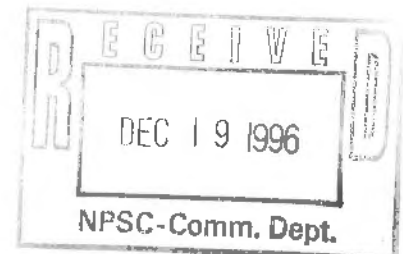

[1] Rates and charges do not include E911 Transport. See c., following.

[2] Rounded to nearest 1,000 main and equivalent main stations (excluding all types of WATS terminations). This count is based upon the maximum number of the above stated main stations in service during the most current 12 month period at the time service is established. This count will be adjusted annually to update the Provider's billing, with the applicable 12 month period being the 12 months ending with the calendar year.

[3] Future Offering. Charges to be developed as demand for SR is required.

NOTICE

THE INFORMATION CONTAINED IN THIS DOCUMENT IS SUBJECT TO CHANGE.

ARAPAHOE TELEPHONE COMPANY

Exchange and Network
Services Catalog

SECTION 9

Page 19

Release 1

State of Nebraska
Notified: 12-19-96

Effective: 1-2-97

9. CENTRAL OFFICE SERVICES

	USOC	NONRECURRING CHARGE[1]	MONTHLY RATE[1]
(4) Combined Automatic Number Identification and Automatic Location Identification, per 1,000 main stations served[2]	E8V	\$1,337.87	\$63.11
(5) Combined Automatic Number Identification and Automatic Location Identification and Selective Routing, per 1,000 main stations served[2]	E8Z	1,637.87	72.11

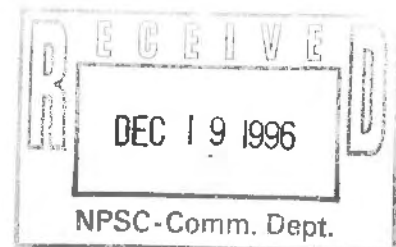

[1] Rates and charges do not include E911 Transport. See c., following.

[2] Rounded to nearest 1,000 main and equivalent main stations (excluding all types of WATS terminations). This count is based upon the maximum number of the above stated main stations in service during the most current 12 month period at the time service is established. This count will be adjusted annually to update the Provider's billing, with the applicable 12 month period being the 12 months ending with the calendar year.

NOTICE

THE INFORMATION CONTAINED IN THIS DOCUMENT IS SUBJECT TO CHANGE.

ARAPAHOE TELEPHONE COMPANY

Exchange and Network
Services Catalog

SECTION 9

Page 20

Release 1

Effective: 1-2-97

State of Nebraska

Notified: 12-19-96

9. CENTRAL OFFICE SERVICES

	USOC	NONRECURRING CHARGE[1]	MONTHLY RATE[1]
c. E911 Transport			
(1) Automatic Number Identification Transport, per 1,000 main stations served[1]	C9B	\$ 40.19	\$ 21.47
(2) Selective Routing Transport, per 1,000 main stations served[1]	C9G	[2]	[2]
(3) Combined Automatic Number Identification and Selective Routing Transport, per 1,000 main stations served[1]	C9O	40.19	21.47
(4) Combined Automatic Number Identification and Automatic Location Identification Transport, per 1,000 main stations served[1]	C9Q	62.13	29.89

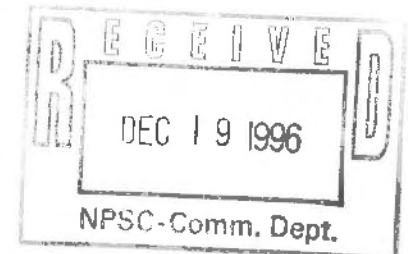

[1] Rounded to nearest 1,000 main and equivalent main stations (excluding all types of WATS terminations). This count is based upon the maximum number of the above stated main stations in service during the most current 12 month period at the time service is established. This count will be adjusted annually to update the Provider's billing, with the applicable 12 month period being the 12 months ending with the calendar year.

[2] Future Offering. Charges to be developed as demand for SR is required.

NOTICE

THE INFORMATION CONTAINED IN THIS DOCUMENT IS SUBJECT TO CHANGE.

ARAPAHOE TELEPHONE COMPANY

Exchange and Network
Services Catalog

SECTION 9

Page 21

Release 1

Effective: 1-2-97

State of Nebraska
Notified: 12-19-96

9. CENTRAL OFFICE SERVICES

	USOC	NONRECURRING CHARGE[1]	MONTHLY RATE[1]
(5) Combined Automatic Number Identification, Automatic Location Identification, and Selective Routing Transport, per 1,000 main stations served[1]	C9T	\$62.13	\$29.89
(6) Additional (optional) E911 Exchange Line terminating at PSAP, each	E8K	600.00	106.00

d. Moves and Changes

Charges for customer requests that necessitate additions, removals, moves or changes of access facilities and/or equipment on Company premises will be based upon costs per request.

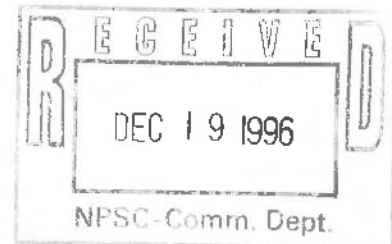

[1] Rounded to nearest 1,000 main and equivalent main stations (excluding all types of WATS terminations). This count is based upon the maximum number of the above stated main stations in service during the most current 12 month period at the time service is established. This count will be adjusted annually to update the Provider's billing, with the applicable 12 month period being the 12 months ending with the calendar year.

NOTICE

THE INFORMATION CONTAINED IN THIS DOCUMENT IS SUBJECT TO CHANGE.

ARAPAHOE TELEPHONE COMPANY

Exchange and Network
Services Catalog

SECTION 9

Page 22

Release 1

State of Nebraska
Notified: 12-19-96

Effective: 1-2-97

9. CENTRAL OFFICE SERVICES

A. Subscriber Records

Subscriber Records are names, addresses and telephone numbers of the Company subscribers. In some areas, service address may be Box Number, Rural Route, etc., not house number or street name. Additional charges, calculated on an individual basis, will apply for any format revision of the data.

1. Terms and Conditions

- a. Subscriber Records information will be furnished for the sole and exclusive purpose of creating a 911 database and shall be used solely for that purpose. Disclosure or use of any information provided through Subscriber Records for other than response to a 911 telephone call is prohibited.
- b. Subscriber Records information provided by the Company is proprietary and may not be duplicated and transferred to a third party except with Company written authorization. Duplicate copies can be made for database back-up to protect the integrity of the system. Upon termination of Subscriber Records service, the customer will return the records to the Company, or upon the Company's approval, records may be destroyed by the customer.
- c. Information obtained when purchasing Subscriber Records may only be used for the expressed purpose of provisioning 911 Service.
- d. Nonpublished and nonlisted telephone numbers are not included in the Subscriber Records offering.
- e. Receipt of Subscriber Records information requires the use of a telephone line, the price of which is not included in the rates and charges for Subscriber Records.
- f. To receive Subscriber Records data, the customer must sign an agreement and, as part of the agreement, the means of delivering the data from the Company to the customer will be described. If the customer elects to have the data delivered in other than electronic means, there may be additional costs which will be assessed to the customer. It is the customer's responsibility to:
 - Provide CPE in the form of compatible computer hardware and software to facilitate the transmission and receipt of Subscriber Records information;
 - Designate an individual to administer the data, including preparation of a database designed to accept Company-formatted records;
 - Develop methods and procedures to facilitate receiving and loading the data using a Company-specified format;



NOTICE

THE INFORMATION CONTAINED IN THIS DOCUMENT IS SUBJECT TO CHANGE.

ARAPAHOE TELEPHONE COMPANY

Exchange and Network
Services Catalog

SECTION 9

Page 23

Release 1

State of Nebraska
Notified: 12-19-96

Effective: 1-2-97

9. CENTRAL OFFICE SERVICES

- Create methods and procedures to ensure that the 911 customer's computer is available to receive Company data at an assigned time;
 - Monitor transmission of data for successful completion;
 - Notify the Company within 24 hours of assigned receipt time if transmission is not successful.
- g. Daily record updates will be provided to the customer unless otherwise negotiated in the contract.
- h. The customer will not be billed for any changes in the number of records that occur during the year. Rather, the customer will be billed for the number of records counted at the time of review on the anniversary date of established service.

2. Rates and Charges

	USOC	NONRECURRING CHARGE	MONTHLY RATE
• Subscriber Records, per 100 Subscriber Telephone Number Records[1]	9RJ1X	ICB	ICB
• Per Service Order for establishing subscriber records	N/A	\$ 10.00	-

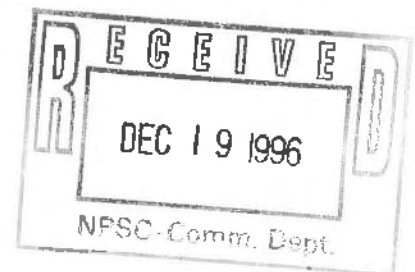

[1] Rounded to the nearest 100 records. This count is based upon the maximum number of subscriber records processed for the 911 Service Area during the most current 12 month period from the date service is established. This number will be based upon the previous 12 months data with an annual review to update the number of records on the anniversary date of the established service.

NOTICE

THE INFORMATION CONTAINED IN THIS DOCUMENT IS SUBJECT TO CHANGE.

ARAPAHOE TELEPHONE COMPANY

Exchange and Network
Services Catalog

SECTION 10

Index Page 1

Release 1

Effective: 1-2-97

State of Nebraska
Notified: 12-19-96

10. MISCELLANEOUS SERVICE OFFERINGS

SUBJECT	PAGE
Alarm Reporting Equipment	9
Billed Number Screening (BNS)	3
Blocking For 10XXX1+/10XXX011+	4
Caller Identification Blocking - All Call	5
Caller Identification Blocking - Per Call	5
Caller Identification Blocking Options	5
Connections of Premises Equipment to Telecommunications Services	6
Data and Teletypewriter Equipment	6
Mileage Charges	1
Multiline Terminating Systems and Communications Systems	10
Pay Per Call Restriction	4
Power Failure Options	11
Recording, Reproducing and Automatic Answering and Recording Equipment	7
Screening/Restriction Services	1
Telephotography Equipment	11
Toll Restriction	3
Toll Screening Service	1

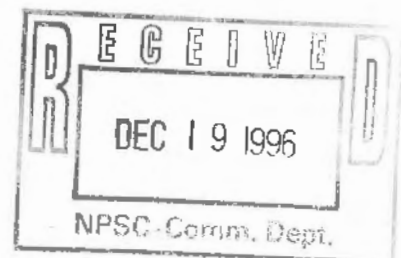

ARAPAHOE TELEPHONE COMPANY

Exchange and Network
Services Catalog

SECTION 10

Page 1

Release 1

Effective: 1-2-97

State of Nebraska
Notified: 12-19-96

10. MISCELLANEOUS SERVICE OFFERINGS

10.1 MILEAGE CHARGES

A. Description

Where, for the purpose of furnishing any of the classes of circuits to which mileage charges apply, as hereinafter specified, it is necessary to provide new construction, such construction will be provided under the terms and conditions governing Construction Charges in Section 4.

10.2 SCREENING/RESTRICTION SERVICES

10.2.1 TOLL SCREENING SERVICE

A. Description

Toll Screening Service provides toll access screening options which allow a customer to restrict the classes of chargeable calls originating over some or all of their lines.

Toll Screening Service enables a customer, by means of Company operator identification, to provide toll access but restrict (0/0+) outgoing toll calls to only those calls which are charged to the called telephone (collect), a third number, and/or calling card.

Two options, described below, are available with this service. The provision of this service may require some customers to change their existing telephone number.

- Option 1

All local and nonchargeable calls, e.g., calls to "800" numbers, and calls to Company numbers such as repair and public emergency service numbers (such as 911) will be permitted. Calls dialed 1+, including calls to Directory Assistance, will not be permitted. Calls dialed 0-/0+ to Directory Assistance will be permitted if alternate billing is provided.

- Option 2

All local calls, nonchargeable calls and calls dialed 1+ will be permitted. With this option, the customer assumes responsibility for all calls dialed 1+ and indemnifies and saves the Company harmless against claims resulting from abuse or fraudulent use of the service.

B. Terms and Conditions

1. Toll Screening Service is furnished in all exchanges where facilities and operating conditions permit.
2. The Company reserves the right to restrict the screening classes or combinations of classes to standard arrangements.

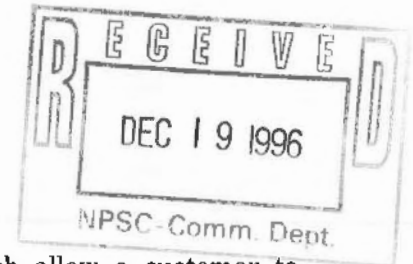

NOTICE

THE INFORMATION CONTAINED IN THIS DOCUMENT IS SUBJECT TO CHANGE.

ARAPAHOE TELEPHONE COMPANY

Exchange and Network
Services Catalog

SECTION 10

Page 2

Release 1

Effective: 1-2-97

State of Nebraska

Notified: 12-19-96

10. MISCELLANEOUS SERVICE OFFERINGS

3. Toll Restriction cannot be applied to lines or trunks using Toll Screening Service.

C. Rates and Charges

	USOC	NONRECURRING CHARGE[1]	MONTHLY RATE
• Per Toll Access Line	SRG	\$ 10.00	\$ 3.00
• To change restriction option, per occasion	NRCK5	10.00	-

[1] Nonrecurring charges do not apply to 0+ Screening only.

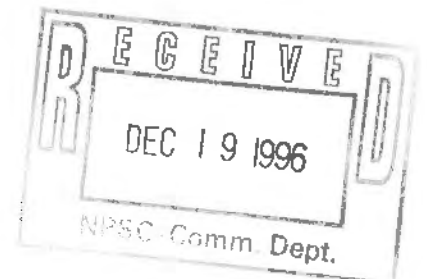

NOTICE
THE INFORMATION CONTAINED IN THIS DOCUMENT IS SUBJECT TO CHANGE.

ARAPAHOE TELEPHONE COMPANY

Exchange and Network
Services Catalog

SECTION 10

Page 3

Release 1

Effective: 1-2-97

State of Nebraska

Notified: 12-19-96

10. MISCELLANEOUS SERVICE OFFERINGS

10.2.2 BILLED NUMBER SCREENING (BNS)

A. Description

BNS prohibits collect and/or third number billed calls from being charged to BNS equipped numbers. Callers attempting to place a collect or third number billed call using a BNS number for billing will be advised by an operator that such billing is unauthorized and the call will not be completed until other payment or billing arrangements are made.

B. Terms and Conditions

1. BNS is subject to the availability of facilities.
2. Collect and/or third number billed calls originating from locations that do not have screening capabilities may not be capable of being intercepted and denied and will be billed, e.g. International calls and calls that do not go through the Billing Validation Authority (BVA) data base.
3. Provision of BNS does not alleviate customer responsibility for completed toll calls.
4. BNS may be used with other Company toll screening/blocking services (e.g. Toll Restriction, Blocking for 10XXX1+/10XXX011+, etc.).
5. This service is available to customers at no charge.

10.2.3 TOLL RESTRICTION

A. Description

Toll Restriction provides for exchange access lines or trunks to be restricted from dialing billable toll calls. Local directory assistance calls are allowed. Attempted violation of the restrictions are routed to an announcement.

B. Terms and Conditions

1. This service is offered, subject to the availability of existing CO facilities, to individual line residence, individual line business and dial switching type customers.
2. Provision of Toll Restriction does not alleviate customer responsibility for completed toll calls.
3. Subscription to services that incorporate Toll Restriction may prevent the completion of 1-plus local calls.
4. Toll Restriction may include Billed Number Screening.

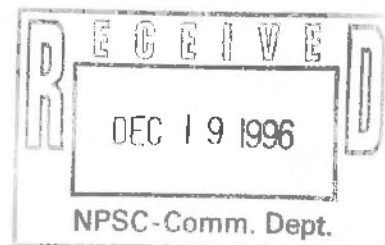

NOTICE

THE INFORMATION CONTAINED IN THIS DOCUMENT IS SUBJECT TO CHANGE.

ARAPAHOE TELEPHONE COMPANY

Exchange and Network
Services Catalog

SECTION 10

Page 4

Release 1

Effective: 1-2-97

State of Nebraska

Notified: 12-19-96

10. MISCELLANEOUS SERVICE OFFERINGS

C. Rates and Charges

	USOC	NONRECURRING CHARGE	MONTHLY RATE
• Business, per line or trunk arranged	RTY	\$ 10.00	\$ 2.00
• Residence, per line	RTY	-	2.00

10.2.4 PAY PER CALL RESTRICTION

A. Description

Pay Per Call Restriction enables individual residence or business exchange access line customers to prohibit dialing of calls with designated Network Access Service (NAS) and 900 prefixes.

B. Terms and Conditions

1. This service is offered subject to availability of existing central office facilities and capabilities.
2. Nonrecurring charges will not apply the first time this service is installed. Appropriate nonrecurring charges will apply for subsequent installations on the same line.

C. Rates and Charges

	USOC	NONRECURRING RESIDENCE	NONRECURRING BUSINESS		MONTHLY RATE
• Restrictions of calls with the designated NAS and 900 prefixes, per line					
- Initial Installation	RTVXN	-	-		-
- Subsequent installation on same line	RTVXN	\$ 10.00	\$ 10.00		-

10.2.5 BLOCKING FOR 10XXX1+/10XXX011+

A. Description

This service prevents 10XXX1+ and 10XXX011+ calls from being completed. Blocked calls will be routed to an announcement.

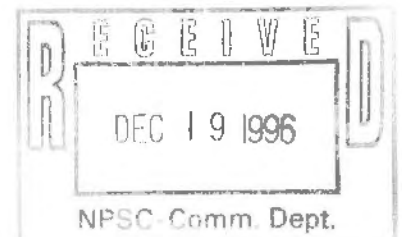

NOTICE

THE INFORMATION CONTAINED IN THIS DOCUMENT IS SUBJECT TO CHANGE.

ARAPAHOE TELEPHONE COMPANY

Exchange and Network
Services Catalog

SECTION 10

Page 5

Release 1

Effective: 1-2-97

State of Nebraska

Notified: 12-19-96

10. MISCELLANEOUS SERVICE OFFERINGS

B. Terms and Conditions

1. This service is offered subject to the availability of existing central office facilities.
2. Provision of 10XXX1+/10XXX011+ Blocking does not alleviate customer responsibility for completed toll calls.

C. Rates and Charges

	USOC	NONRECURRING CHARGE	MONTHLY RATE
• Per Line, Trunk or Network Access Register arranged	RTVXY	\$ 10.00	\$ 0.10

10.3 CALLER IDENTIFICATION BLOCKING OPTIONS

10.3.1 CALLER IDENTIFICATION BLOCKING - PER CALL

A. Description

Enables a customer to control the disclosure of his/her name and/or telephone number to a subscriber of Caller Identification (where technically feasible) by temporarily changing the public/private status indicator of the telephone number. A customer must dial a code before each call to change the indicator from public to private. "Public status" allows delivery of the name and/or telephone number. "Private status" prevents delivery of the name and/or telephone number. Per Call Blocking is provided at no charge.

B. Rates and Charges

	USOC	MONTHLY RATE
• Per Call	N/A	-

10.3.2 CALLER IDENTIFICATION BLOCKING - ALL CALL

A. Description

Provides a permanent private indicator on a customer's line. Once the blocking is established on the customer's line, the private status cannot be deactivated by the customer. Federal, State, and local law enforcement agencies and non-profit domestic violence agencies may be provided additional arrangements for private status and/or all call blocking, on a line-by-line basis, at no charge.

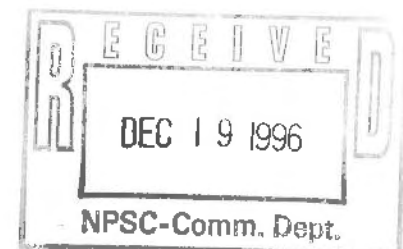

NOTICE

THE INFORMATION CONTAINED IN THIS DOCUMENT IS SUBJECT TO CHANGE.

ARAPAHOE TELEPHONE COMPANY

Exchange and Network
Services Catalog

SECTION 10

Page 6

Release 1

State of Nebraska

Notified: 12-19-96

Effective: 1-2-97

10. MISCELLANEOUS SERVICE OFFERINGS

B. Rates and Charges

	USOC	NONRECURRING CHARGE	MONTHLY RATE
• All Call			
- Business	NKM	-	\$ 2.00
- Residence	NKM	-	1.00

10.4 CONNECTIONS OF PREMISES EQUIPMENT TO TELECOMMUNICATIONS SERVICES

10.4.1 DATA AND TELETYPEWRITER EQUIPMENT

A. Description

Customer data transmitting and receiving equipment may be connected to facilities of the Company for the transmission and reception of data signals.

B. Rates and Charges

1. Data Access Arrangement

For connection of customer-provided data transmitting and/or receiving equipment or communications systems.

	USOC	NONRECURRING CHARGE	MONTHLY RATE
• Basic arrangement for manual operation	CDT	[1]	\$ 2.00
• Arrangement for unattended sending and receiving through a voltage type control interface, each	CBS	[1]	5.50
• Arrangement for unattended sending and receiving through a contact closure type control interface, each	CBT	[1]	4.20
- Power supply for use with contact closure type interface when not supplied by customer, each	CBV	[1]	1.20

[1] Premises Work Charges, specified in 13.1, apply.



NOTICE

THE INFORMATION CONTAINED IN THIS DOCUMENT IS SUBJECT TO CHANGE.

ARAPAHOE TELEPHONE COMPANY

Exchange and Network
Services Catalog

SECTION 10

Page 7

Release 1

Effective: 1-2-97

State of Nebraska
Notified: 12-19-96

10. MISCELLANEOUS SERVICE OFFERINGS

10.4.2 RECORDING, REPRODUCING AND AUTOMATIC ANSWERING AND RECORDING EQUIPMENT

A. General

1. Basis of Connection.

Customer-provided recording, reproducing and automatic answering and recording equipment may be connected with the facilities of the Company subject to the following conditions:

- a. The equipment provided by the customer will be connected with telecommunications services defined as exchange lines.
- b. Customer-provided recording, reproducing and automatic answering and recording equipment shall not be used to interconnect any line or channel of the Company with any other communications lines or channel of the Company or of any other person, except as expressly authorized in 2.5.2.B.
- c. Customer-provided recording, reproducing and automatic answering and recording equipment may be connected with facilities of the Company only when and for so long as the customer subscribes to a sufficient number of telephone lines to handle adequately the volume of telephone calls received without interfering with any of the services offered by the Company.

In the event that the use of customer-provided equipment causes such interference, the Company shall have the right to discontinue service without prior notification to the customer.

- d. Use of customer-provided reproducing equipment or customer-provided automatic answering and recording equipment in association with the Company facilities for public announcements are subject to the following conditions:
 - For purposes of identification, customers who transmit recorded public announcements over facilities provided by the Company must include in the recorded message the name of the organization or individual responsible for the service and the address at which the service is provided.
 - Customers transmitting factual public announcements such as Time, Weather, Stock Market quotations, Airline schedules and similar information are excluded from the preceding condition.
 - Failure to comply with the provisions of this Catalog shall be cause for termination of the service.

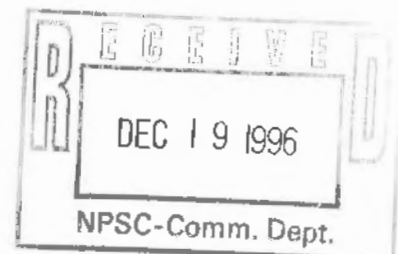

NOTICE

THE INFORMATION CONTAINED IN THIS DOCUMENT IS SUBJECT TO CHANGE.

ARAPAHOE TELEPHONE COMPANY

Exchange and Network
Services Catalog

SECTION 10

Page 8

Release 1

Effective: 1-2-97

State of Nebraska

Notified: 12-19-96

10. MISCELLANEOUS SERVICE OFFERINGS

B. Rates and Charges

1. Connecting Equipment

	USOC	NONRECCURING CHARGE	MONTHLY RATE
• Recorder Connector Equipment for connecting attended customer-provided recording equipment to Company facilities			
• Recorder Connector			
- With automatic recorder tone	RCT	[1]	\$ 2.00
- For permanent installation	RCZ	[1]	2.00
• Recorder Coupler Equipment			
- Arrangement to provide connection of attended or unattended customer-provided recording, reproducing and automatic answering and recording equipment, each			
- With disconnect supervision	RDL	[1]	\$ 4.15
- Without disconnect supervision	GTS	[1]	2.15
- Arrangement to provide connection of customer-provided answer-only terminal equipment			
- Per line equipped where two-way transmission is required	RDMZR	[1]	3.45
- Per line equipped where automatic volume limiting is required	RDY	[1]	4.15

[1] Premises Work Charges. specified in 13.1, apply.

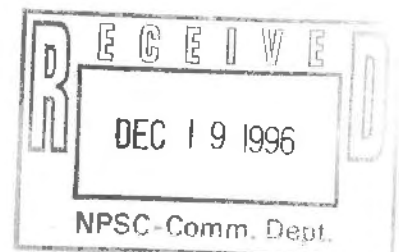

NOTICE

THE INFORMATION CONTAINED IN THIS DOCUMENT IS SUBJECT TO CHANGE.

ARAPAHOE TELEPHONE COMPANY

Exchange and Network
Services Catalog

SECTION 10

Page 9

Release 1

Effective: 1-2-97

State of Nebraska

Notified: 12-19-96

10. MISCELLANEOUS SERVICE OFFERINGS

10.4.3 ALARM REPORTING EQUIPMENT

A. General

Except as otherwise provided in B., following, customer-provided Alarm Reporting equipment which sends dial pulses corresponding to a predetermined telephone number and then transmits a prerecorded voice alarm message may be connected to the facilities of the Company subject to the following conditions:

1. Such equipment may be connected only to individual dial central office station lines.
2. Connection to the Company's facilities shall be made only through use of a connecting arrangement provided by the Company. The customer-provided connecting equipment seizes the associated line upon receipt of a signal from the customer-provided equipment, reconstitutes the dial pulses received from the customer-provided equipment, restricts the transmission path to outward transmissions and automatically terminates the connection at the conclusion of the voice alarm message.
3. Customer-provided Alarm Reporting equipment shall not be used to interconnect any line or channel of the Company with any other communications line or channel of the Company or of any other person.

B. Moves or Changes

Customer-provided alarm reporting equipment connected to the telecommunications network in accordance with 1. preceding, prior to January 1, 1980, may remain connected and be moved and reconnected for the life of the equipment without registration unless subsequently modified. New installations of customer-provided terminal equipment and communications systems subject to Part 68 of the Federal Communications Commission's Rules and Regulations must be connected to the telecommunications network in accordance with FCC rules and regulations.

C. Rates and Charges

	USOC	NONRECURRING CHARGE	MONTHLY RATE
• Alarm Coupler	CAU	[1]	\$ 1.90
- Combined Alarm Coupler with Signaling Unit	SU4	[1]	5.15
• Arrangement to provide connection of customer-provided originate only or originate and answer terminal equipment, per line equipped	SU6AQ	[1]	3.35

[1] Premises Work Charges, specified in 13.1, apply

NOTICE

THE INFORMATION CONTAINED IN THIS DOCUMENT IS SUBJECT TO CHANGE.



ARAPAHOE TELEPHONE COMPANY

Exchange and Network
Services Catalog

SECTION 10

Page 10

Release 1

Effective: 1-2-97

State of Nebraska

Notified: 12-19-96

10. MISCELLANEOUS SERVICE OFFERINGS

10.4.4 MULTILINE TERMINATING SYSTEMS AND COMMUNICATIONS SYSTEMS

A. Description

Customer Multiline Terminating Systems and Communications Systems may be connected to the telecommunications network by means of suitable connecting arrangements.

B. Rates and Charges

	USOC	NONRECURRING CHARGE	MONTHLY RATE
<ul style="list-style-type: none"> • Arrangement to permit connection of a customer-provided and maintained attendant position to an exchange trunk <ul style="list-style-type: none"> - Per automatic arrangement provided in connection with two-way service 	CD9	[1]	\$ 5.75
<ul style="list-style-type: none"> • Arrangement to permit connection of customer-provided and maintained switching equipment to attendant positions to an exchange trunk line <ul style="list-style-type: none"> - Per automatic arrangement provided in connection with two-way service (outward only from switching equipment) 	CDH	[1]	5.75
<ul style="list-style-type: none"> • Arrangement to permit the connection of a customer-provided communication system to a special Company trunk for access to the long distance switchboard <ul style="list-style-type: none"> - Per automatic arrangement provided in connection with two-way service 	CED	[1]	5.75
<ul style="list-style-type: none"> • Arrangement to provide for automatic connection of customer provided terminal equipment, per line equipped 	STC	[1]	3.65
<ul style="list-style-type: none"> • Arrangement to provide for automatic connection of customer-provided voice communications systems and/or terminal equipment to Company facilities <ul style="list-style-type: none"> - Per exchange line, PBX trunk or terminal equipment[2] 	STP	[1]	6.00

[1] Premises Work Charges, specified in 13.1, apply.

[2] Single line installation will not be provided.



NOTICE

THE INFORMATION CONTAINED IN THIS DOCUMENT IS SUBJECT TO CHANGE.

ARAPAHOE TELEPHONE COMPANY

Exchange and Network
Services Catalog

SECTION 10

Page 11

Release 1

State of Nebraska
Notified: 12-19-96

Effective: 1-2-97

10. MISCELLANEOUS SERVICE OFFERINGS

10.4.5 POWER FAILURE OPTIONS

A. Description

1. The following equipment is associated with power failure arrangements for use during periods of commercial power failure at the customer's premises.
2. This arrangement is associated with connecting arrangement CD9 and CDH service is operative only during commercial power failure.

B. Rates and Charges

	USOC	NONRECURRING CHARGE	MONTHLY RATE
• Power failure arrangement, per connecting arrangement	PFC	[1]	\$ 3.00

[1] Premises Work Charges, specified in 13.1, apply.

10.4.6 TELEPHOTOGRAPHY EQUIPMENT

A. General

Except as otherwise provided in B., following, telephotograph equipment provided by the press, law enforcement agencies, armed forces, civilian defense agencies or the United States Weather Bureau may be used in connection with the exchange and toll service lines of the Company, under the following conditions:

1. Telephotograph equipment provided by the Press may be connected to lines of the Company for use by the Press for the transmission and reception of pictures and similar material for publication. Telephotograph equipment provided by law enforcement agencies may be connected to lines of the Company for use by law enforcement agencies for the transmission and reception of fingerprints, ballistic data, identification photographs and similar law enforcement material. Telephotograph equipment provided by the armed forces of the United States may be connected to the lines of the Company for use by the armed forces of the United States for transmission and reception of information of military necessity essential to the national defense. Telephotograph equipment provided by civilian defense agencies may be connected to lines of the Company for use by civilian defense agencies for the transmission and reception of information essential for the discharge of their responsibilities in emergencies. Telephotograph equipment provided by the United States Weather Bureau may be connected to the lines of the Company for use by the Weather Bureau for the transmission and reception of weather information.

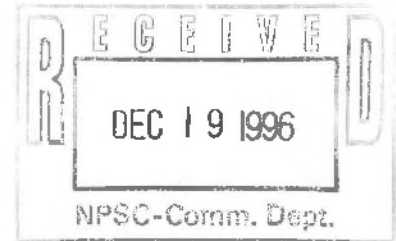

NOTICE

THE INFORMATION CONTAINED IN THIS DOCUMENT IS SUBJECT TO CHANGE.

ARAPAHOE TELEPHONE COMPANY

Exchange and Network
Services Catalog

SECTION 10

Page 12

Release 1

Effective: 1-2-97

State of Nebraska

Notified: 12-19-96

10. MISCELLANEOUS SERVICE OFFERINGS

2. Customer telephotograph equipment may be connected either by direct physical connection or by acoustic or inductive coupling. Direct physical connection may be made only by means of connection equipment furnished by the Company. The connection of the telephotograph equipment may be made by the customer only to the terminals of the connection equipment.
3. Portable connection equipment will be furnished, if desired, for use with portable telephotograph equipment of the customer.
4. The telephotograph equipment may be used in connection with any class of business service, except coin box service, furnished to the press, law enforcement agency, the armed forces, civilian defense agencies, or the United States Weather Bureau or made available to them under a joint user arrangement. Portable connection equipment may be used also at private branch exchange stations in guest rooms of hotels, subject to the consent of the hotel concerned.
5. The Company assumes no responsibility for the quality of, or defects in, the material transmitted or received regardless of cause.

B. Moves or Changes

Customer-provided telephotograph equipment that is connected to the telecommunications network in accordance with A.1., preceding, prior to July 1, 1979, may remain connected and be moved and reconnected for the life of the equipment without registration unless subsequently modified. New installations of customer-provided terminal equipment and communications systems subject to Part 68 of the Federal Communications Commission's Rules and Regulations must be connected to the telecommunications network in accordance with FCC rules and regulations.

C. Rates and Charges

	USOC	MONTHLY RATE
• For connection equipment, each	367	\$ 1.20

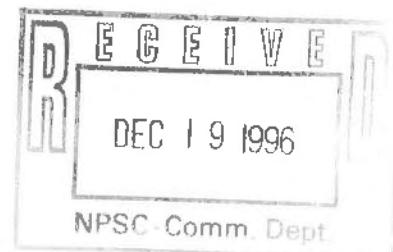

ARAPAHOE TELEPHONE COMPANY

Exchange and Network
Services Catalog

SECTION 11

Index Page 1

Release 1

State of Nebraska

Notified: 12-19-96

Effective: 1-2-97

11. OBSOLETE EXCHANGE SERVICES

SUBJECT

PAGE

Remote Location Line Service 1

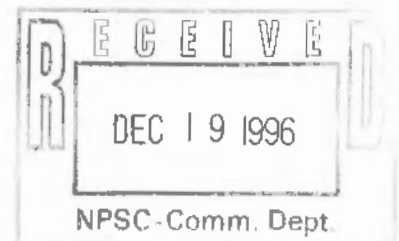

ARAPAHOE TELEPHONE COMPANY

Exchange and Network
Services Catalog

SECTION 11

Page 1

Release 1

State of Nebraska

Notified: 12-19-96

Effective: 1-2-97

11. OBSOLETE EXCHANGE SERVICES

11.1. REMOTE LOCATION LINE SERVICE

A. Description

Remote Location Line Service (RLLS) is obsolete and will not be offered to new customers as of January 1, 1997. This is a service where a call placed from a station to a customer's telephone number in one central office is automatically forwarded by the Company central office equipment to another customer designated station. RLLS is offered for Local Exchange Service only where in the Company's judgment, central office equipment and facilities allow a measured service offering.

B. Terms and Conditions

1. One directory listing covering the exchange in which the call forwarding central office is located is provided with this service.
2. RLLS if offered subject to the availability of facilities.
3. RLLS may not be terminated in a public coin telephone.
4. Identification of the originating telephone number will not be provided to RLLS customers.
5. RLLS is provided on the condition that the customer subscribe to sufficient features or facilities to adequately handle calls without interfering or impairing services offered by the Company. If, in the opinion of the Company, additional RLLS features or facilities are needed to avoid interference with or impairment of services offered by the Company, the customer will be required to subscribe to such additional features or facilities. In the event the customer refuses to subscribe to adequate RLLS features or facilities, the service shall be subject to termination.
6. The calling party is responsible for toll charges associated with calls between the originating station and the call forwarding location. The RLLS customer is responsible for the applicable customer dialed station-to-station charges associated with messages between the call forwarding location and the terminating station. On local calls, the remote Call Forwarding customer is responsible for the payment of applicable local measured service usage charges.

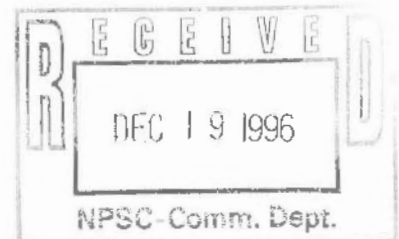

NOTICE

THE INFORMATION CONTAINED IN THIS DOCUMENT IS SUBJECT TO CHANGE

ARAPAHOE TELEPHONE COMPANY

Exchange and Network
Services Catalog

SECTION 11

Page 2

Release 1

State of Nebraska

Notified: 12-19-96

Effective: 1-2-97

11. OBSOLETE EXCHANGE SERVICES

C. Rates and Charges

1. The following rates and charges apply to RLLS Service.

	USOC	NONRECURRING CHARGE[1,2]	MONTHLY RATE
• Per first access line	RCF	\$ 33.00	\$ 16.00
• Each additional line	RCA	33.00	16.00

2. The rates and charges, specified in 1., apply for RLLS on local calls and are in addition to the following Measured Service usage charges.

CALL AREA	DISTANCE IN MILES	DIAL STATION-TO-STATION	
		INITIAL MINUTE RATE	EACH ADD'L. MINUTE RATE
Zone 1	0-10	\$ 0.05	\$ 0.010
Zone 2	11-15	0.07	0.013
Zone 3	16-20	0.09	0.015
Zone 4	21-25	0.11	0.017
Zone 5	26-35	0.13	0.019

- a. The wire centers within an exchange which are contiguous to the wire center from which a call is forwarded will always be included in the 0-10 mile call area.
- b. The timing of local messages is the same as specified for toll messages in 5.2.(C)(2).

[1] The nonrecurring charge associated with each additional line applies only if the additional line is installed on a subsequent order. There is no additional charge when it is installed on the same order as the first access line. When one or more additional lines (RCA) are installed on the same line at the same time, only one nonrecurring charge applies.

[2] When at the request of the customer a number change is requested for the call forwarding location, the number to which calls are forwarded or both, nonrecurring charges apply.



NOTICE

THE INFORMATION CONTAINED IN THIS DOCUMENT IS SUBJECT TO CHANGE

ARAPAHOE TELEPHONE COMPANY

Exchange and Network
Services Catalog

SECTION 13

Index Page 1

Release 1

Effective: 1-2-97

State of Nebraska

Notified: 12-19-96

13. CUSTOMER PREMISES WIRE AND MAINTENANCE PLANS

SUBJECT	PAGE
Customer Premises Wire	1
Premises Wire Maintenance.....	15

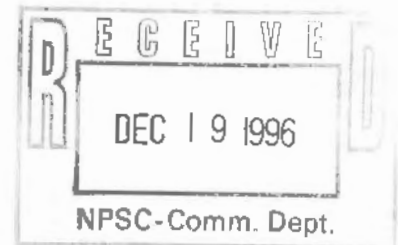

ARAPAHOE TELEPHONE COMPANY

Exchange and Network
Services Catalog

SECTION 13

Page 1

Release 1

Effective: 1-2-97

State of Nebraska

Notified: 12-19-96

13. CUSTOMER PREMISES WIRE AND MAINTENANCE PLANS

13.1 CUSTOMER PREMISES WIRE

A. Description

Customer premises wire is defined as that wire including connectors, blocks and jacks on a customer's premises that extends between the demarcation point and those connectors, blocks and jack locations within the same building to which terminal equipment can be connected for access to the exchange access line.

Premises wire may be installed and/or maintained by the Company or the customer. Where installation or maintenance is provided by the Company, rates and charges specified in this section will apply.

Billable work performed on the network side of the demarcation point can be found under Premises Work charges in Section 3.

B. Definitions

Change

The change of premises wire at the request of the customer.

Complex Premises Wire

Wiring including connectors, blocks and jacks on a customer's premises whose equipment includes common equipment such as multiline telephone systems, multifunction systems and data equipment jacks (programmable, universal and fixed loop loss), etc.

Demarcation Point

The term "demarcation point" means the point of connection, provided and maintained by the Company, to which the Company service and the property owner's or customer's facilities are connected. The demarcation point is normally located near the point where the Company facilities enter the customer's building or property. The property owner or customer is responsible for service on the customer side of the demarcation point(s).

Estimate

A broad statement of expected price, which is not necessarily the price the customer will be billed.

Firm Bid

A firm price, in writing, for a stated purpose and good for a limited time period. Quotations accepted by the customer will be billed at the stated price, regardless of the actual costs incurred by the installation forces.

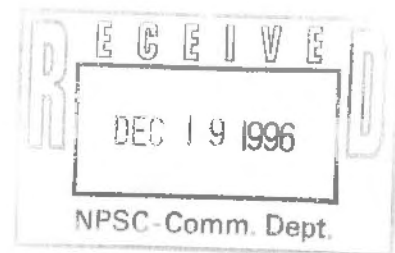

NOTICE

THE INFORMATION CONTAINED IN THIS DOCUMENT IS SUBJECT TO CHANGE.

ARAPAHOE TELEPHONE COMPANY

Exchange and Network
Services Catalog

SECTION 13

Page 2

Release 1

Effective: 1-2-97

State of Nebraska

Notified: 12-19-96

13. CUSTOMER PREMISES WIRE AND MAINTENANCE PLANS

Flat Installation Charge

A nonrecurring charge(s) which applies to noncomplex wire and jack installation.

Residential Wire Maintenance Service (Monthly Maintenance Agreement)

A monthly rate paid in lieu of a nonrecurring charge, line testing charge (if applicable) and time and material charges for repairing inside wire.

Moves

A customer-requested move of premises wiring from one location to another on the same premises.

Network Interface

Same term as "demarcation point".

Noncomplex Premises Wire

Noncomplex customer premises wire is defined as that wire including connectors, blocks and jacks on a customer's premises that extends between the demarcation point and those connectors, blocks and jack locations to which terminal equipment can be connected for access to the exchange access line.

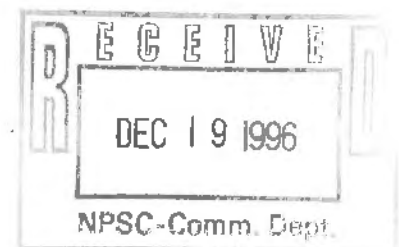

NOTICE

THE INFORMATION CONTAINED IN THIS DOCUMENT IS SUBJECT TO CHANGE.

ARAPAHOE TELEPHONE COMPANY

Exchange and Network
Services Catalog

SECTION 13

Page 3

Release 1

Effective: 1-2-97

State of Nebraska

Notified: 12-19-96

13. CUSTOMER PREMISES WIRE AND MAINTENANCE PLANS

Nonrecurring Charge, Unregulated [1]

Charge for work involved in establishing a Company Premises Wire Maintenance Plan. The charge may apply for record work if the customer transfers the service to a different location.

Premises Visit Charge

A premises visit or series of visits by an installer or repair person for the purpose of performing billable premises work requested by the customer or customer's representative.

Rearrangement

Work required to remove and/or replace premises wiring and/or jacks to accommodate a customer's need for a relocation of the wire.

Time and Material (T&M) Charges

Work performed on a customer's premises by a Company employee or representative at the customer's request and not covered by other charges. This includes work preparation, actual work and cleanup. Any work required to establish or reestablish network access up to and including the demarcation point is excluded.

Trouble Isolation Charge

A nonrecurring charge which applies when the Company makes a repair or trouble isolation visit to the customer's premises to test the central office line, up to the demarcation point, and the line tests clear and trouble is not found in the Company's facilities.

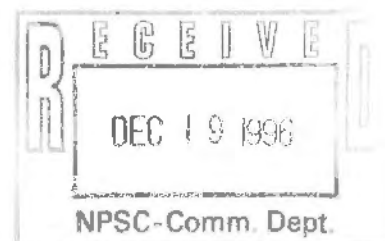

[1]

A separate nonrecurring charge will not apply to work assessed time and material charges. These administrative costs are included in the first time increment.

NOTICE

THE INFORMATION CONTAINED IN THIS DOCUMENT IS SUBJECT TO CHANGE.

ARAPAHOE TELEPHONE COMPANY

Exchange and Network
Services Catalog

SECTION 13

Page 4

Release 1

Effective: 1-2-97

State of Nebraska
Notified: 12-19-96

13. CUSTOMER PREMISES WIRE AND MAINTENANCE PLANS

Business Wire Maintenance Service

Business Wire Maintenance Service is a monthly charge for business customer paid in lieu of time and material charges for repairs associated with premises wire. This plan provides line testing, trouble isolation, and the repair of premises wire and connected jacks.

C. Terms and Conditions

1. The customer may request an estimate or a firm bid before ordering wire installation work done. When an estimate is provided, the estimate is not binding on the Company and the charge to be billed will be based on the actual time and material charge incurred. When a firm bid is provided at customer request, the charge to be billed is the amount quoted to the customer for the work requested.
2. The customer or property owner must provide and maintain, or pay the expense of, rights-of-way, poles, attachments, conduits or other supporting structures required for the placing of premises wire.
3. Premises Work Charges apply per service call when billable premises work is performed on premises wire. Such charges are due and payable when billed.

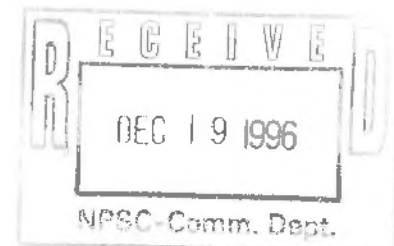

NOTICE

THE INFORMATION CONTAINED IN THIS DOCUMENT IS SUBJECT TO CHANGE.

ARAPAHOE TELEPHONE COMPANY

Exchange and Network
Services Catalog

SECTION 13

Page 5

Release 1

State of Nebraska

Notified: 12-19-96

Effective: 1-2-97

13. CUSTOMER PREMISES WIRE AND MAINTENANCE PLANS

4. Premises Visit Charge

a. Installation

- Premises Visit Charge applies when:
 - Deregulated work is performed beyond the demarcation point.
 - Flat Installation Charge does not apply.

b. Maintenance

- Premises Visit Charge applies when:
 - Deregulated work is performed beyond the demarcation point.
 - The customer does not subscribe to a Premises Wire Maintenance Plan and requests repair work.
 - Trouble Isolation Charge does not apply.

c. Premises Visit Charge is waived when:

- Repair work is performed beyond the demarcation point for a customer subscribing to a Premises Wire Maintenance Plan and the customer requests billable installation work to be performed while the technician is on the premises. The billable time will begin with the first increment.
- When more than one order involving installation or repair is worked by the same technician, consecutively, on the same contiguous property and travel from one order location to another order location is five minutes or less, the trip charges on the additional orders are waived
- When flat rate installation work is performed and Time and Material work is also performed on the same order, the Premises Visit Charge will be waived.

5. Flat Installation Charge

A nonrecurring charge(s) which applies to noncomplex wire and jack installation. Included within the Flat Installation charge is the Premises Visit Charge (travel time) and simple material e.g., staples, screws, nails, tape, 2 to 6 pr inside wire, faceplates and noncomplex jacks. Additional material charges may apply, if applicable.

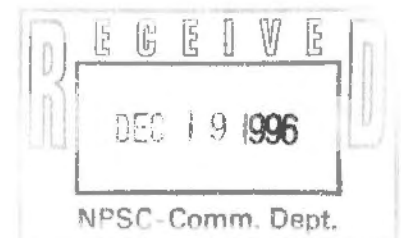

NOTICE

THE INFORMATION CONTAINED IN THIS DOCUMENT IS SUBJECT TO CHANGE.

ARAPAHOE TELEPHONE COMPANY

Exchange and Network
Services Catalog

SECTION 13

Page 6

Release 1

Effective: 1-2-97

State of Nebraska

Notified: 12-19-96

13. CUSTOMER PREMISES WIRE AND MAINTENANCE PLANS

6. Time and Material Charges

a. Time and Material Charges apply to all customer-requested nonregulated wiring work involving:

- Installations (Business - Complex)
- Installations (Residence - Complex)
- Moves
- Changes
- Removals
- Rearrangements
- Replacements
- Maintenance
- Prewiring

b. Simple materials for noncomplex residence and business customers are not billed separately. The following items are considered "simple" materials.

Non-billable materials include: Standard wire, simple jacks, staples, screws, nails, tape, connectors, etc.

c. Time and Material Charges apply separately for each premises involved, per service call, when billable premises work is performed on premises wire. The minimum billable time is one half hour.

d. Only one initial Time and Material Charge applies when, for Company reasons, more than one Company technician is involved in performing billable premises work on the same service order. Additional Time and Material Charges will be calculated by totaling the remaining billable work time performed by all technicians.

e. Initial Time and Material Charges apply when a Company repair technician, while on the customer's premises, provides additional service(s) at the customer's request. In addition, the rates and charges applicable for the additional service will apply.

f. The initial and any additional Time and Material Charges will apply for the first and subsequent move of equipment and/or wire on the customer's premises, made at the customer's request, as a result of the customer's redecorating or any other customer activity requiring the first and subsequent visit for moves.

g. Time and Material Charges will apply for work performed on all RJ21 and other interpositioned network channel terminating equipment located on the customer's side of the demarcation point.

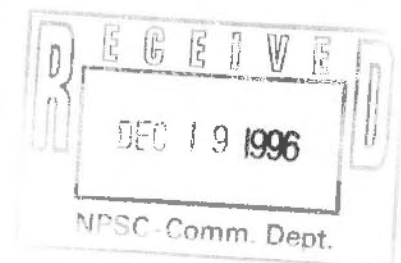

NOTICE

THE INFORMATION CONTAINED IN THIS DOCUMENT IS SUBJECT TO CHANGE.

ARAPAHOE TELEPHONE COMPANY

Exchange and Network
Services Catalog

SECTION 13

Page 7

Release 1

Effective: 1-2-97

State of Nebraska

Notified: 12-19-96

13. CUSTOMER PREMISES WIRE AND MAINTENANCE PLANS

h. Time and Material Charges do not apply to the following work:

- To move or change a customer's telephone service if required or initiated by the Company.
- To install, move or change telephone service located on a customer's premises but used exclusively by the Company for maintenance or training activities.
- The "from" portion of work involved in a transfer of service from one premises to another.
- Disconnection of access line services providing no other work subject to time and material charges is involved.
- Maintenance work performed when the customer is a subscriber of a Company Wire Maintenance Plan.
- Installation of noncomplex wire and jacks.

7. Trouble Isolation Charge

- a. A Trouble Isolation Charge applies when the Company makes a repair or trouble isolation visit to the customer's premises to test the central office line, up to the demarcation point, and the line tests clear and trouble is not found in the Company's facilities.
- b. The charge will not apply to a customer who subscribes to a Company Premises Wire Maintenance Plan.

D. Warranties for Installation and Repair of Premises Wire

1. Limited Thirty-Day Installation Warranty

a. Coverage

The Company warrants the premises telecommunications wiring which it has installed against defects and malfunctions for a period of 30 days in the case of both complex and noncomplex wire from the date the telecommunications service utilizing the wire begins. If there is a defect or malfunction, the Company will, at its option, either repair or replace this wiring at no charge to the customer if the defect or malfunction is reported to an authorized Company representative within the warranty period. If replacement parts are used in making repairs, these parts may be refurbished or may contain refurbished materials.

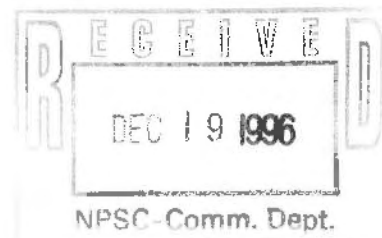

NOTICE

THE INFORMATION CONTAINED IN THIS DOCUMENT IS SUBJECT TO CHANGE.

ARAPAHOE TELEPHONE COMPANY

Exchange and Network
Services Catalog

SECTION 13

Page 8

Release 1

Effective: 1-2-97

State of Nebraska

Notified: 12-19-96

13. CUSTOMER PREMISES WIRE AND MAINTENANCE PLANS

b. Exclusions

- (1) This warranty shall not apply to defects and malfunctions resulting from any equipment or service furnished by any person other than the Company, any accident, alteration, abuse, misuse, fire, acts of God such as storms and floods, or any unauthorized repair.
- (2) The Company disclaims any and all implied warranties, including without limitation, warranties of merchantability and fitness for a particular purpose.
- (3) The Company shall not be liable for any incidental or consequential damages, including but not limited to loss, damage or expense directly or indirectly arising from the customer's use of or inability to use this wiring, either separately or in combination with other equipment.

c. Customer Responsibility

- (1) To obtain Company repair service, the customer must call the Company repair number which can be found in the telephone directory, or call any Company Business Office, collect.
- (2) When the repair person arrives and before any work is performed, the customer must present proof of the date the warranty commenced before any warranty work can be performed.

E. Responsibility of the Customer

1. Where the customer elects to install and/or maintain premises wire, such installation and/or maintenance must comply with Part 68 of the FCC Rules and Regulations and the National Electrical Code as well as any applicable local electrical codes.
2. Where customer premises wire is maintained by the customer, the customer is responsible for correcting any service difficulty upon notice from the Company that such wire is causing the difficulty.

F. Violation of Regulations

1. Where any customer-provided premises wire or associated jack has been installed or maintained in violation of Part 68 of the FCC Rules and Regulations, National or applicable local Electrical Codes or Company-provided technical standards, the Company will promptly notify the customer of the violation and will take such immediate action, including the temporary disconnection of premises wire, as is necessary for the protection of the telecommunications network and/or Company employees.

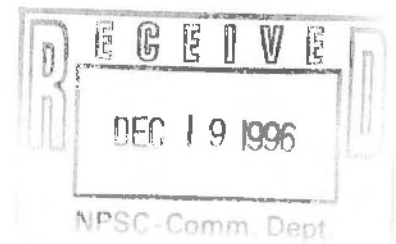

NOTICE

THE INFORMATION CONTAINED IN THIS DOCUMENT IS SUBJECT TO CHANGE.

ARAPAHOE TELEPHONE COMPANY

Exchange and Network
Services Catalog

SECTION 13

Page 9

Release 1

State of Nebraska

Notified: 12-19-96

Effective: 1-2-97

13. CUSTOMER PREMISES WIRE AND MAINTENANCE PLANS

2. The customer shall discontinue use of the customer-provided premises wire and/or associated jacks or correct the violation and notify the Company in writing within ten days after receipt of Company notice of violation that the violation has been corrected.

G. Charges

1. Premises Work Charges - Residence

	USOC	NONRECURRING CHARGE
a. Premises Visit Charge	NRAC	\$ 20.00
b. Time and Material Charges (Installation of Complex Wiring and Prewire)		
• Schedule I (Regular Scheduled Hours)		
Applicable to premises work performed during regularly scheduled business hours.		
- First 30 minute increment or fraction thereof	HRD11	41.00
- Each additional 15 minute increment or fraction thereof	HRDA1	16.00
• Schedule II (After Hours)		
Applicable to premises work performed at hours other than on Schedule I, excluding Sundays and holidays.		
- First 30 minute increment or fraction thereof	HRD12	55.00
- Each additional 15 minute increment or fraction thereof	HRDA2	23.00
• Schedule III (Premium Hours)		
Applicable to premises work performed on Sundays and holidays.		
- First 30 minute increment or fraction thereof	HRD13	65.00
- Each additional 15 minute increment or fraction thereof	HRDA3	26.00



NOTICE

THE INFORMATION CONTAINED IN THIS DOCUMENT IS SUBJECT TO CHANGE.

ARAPAHOE TELEPHONE COMPANY

Exchange and Network
Services Catalog

SECTION 13

Page 10

Release 1

State of Nebraska

Notified: 12-19-96

Effective: 1-2-97

13. CUSTOMER PREMISES WIRE AND MAINTENANCE PLANS

c. Time and Material Charges (Repair)

- Schedule I (Regular Scheduled Work Hours)

Applicable to premises work performed during regularly scheduled business hours.

- First 30 minute increment or fraction thereof	HRD11	41.00
- Each additional 15 minute increment or fraction thereof	HRDA1	16.00

- Schedule II (After Hours)

Applicable to premises work performed at hours other than on Schedule I, excluding Sundays and holidays.

- First 30 minute increment or fraction thereof	HRD12	55.00
- Each additional 15 minute increment or fraction thereof	HRDA2	23.00

- Schedule III (Premium Hours)

Applicable to premises work performed on Sundays and holidays.

- First 30 minute increment or fraction thereof	HRD13	65.00
- Each additional 15 minute increment or fraction thereof	HRDA3	26.00

d. Holidays

Holidays subject to Schedule III charges are:

HOLIDAY

New Year's Day
Memorial Day
Independence Day
Labor Day
Thanksgiving Day
Christmas Day

DAY OBSERVED

January 1
Last Monday in May
July 4
First Monday in September
Fourth Thursday in November
December 25

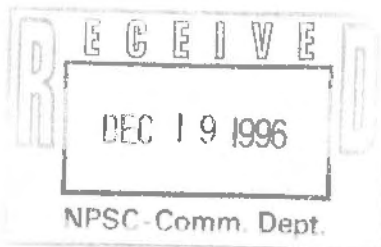

NOTICE

THE INFORMATION CONTAINED IN THIS DOCUMENT IS SUBJECT TO CHANGE.

ARAPAHOE TELEPHONE COMPANY

Exchange and Network
Services Catalog

SECTION 13

Page 11

Release 1

State of Nebraska

Notified: 12-19-96

Effective: 1-2-97

13. CUSTOMER PREMISES WIRE AND MAINTENANCE PLANS

e. Material Used Not Billed[1]

USOC

(Normal repair material)

RJ11C
RJ14C
RJ11W
RJ14W

2 to 6 pr inside wire,
faceplates, staples,
screws, nails, tape,
connectors, etc.

[1] Normal installation and repair materials are included in the first increment rate for residence customers and are not billed separately.

f. Material Used/Billed

USOC	NONRECURRING CHARGE
AKT++ (e.g., AKT57)	\$ 1 to 99 57.00)
BAC++ (e.g., BACO1)	100 to 199 101.00)
CDR++ (e.g., CDR73)	200 to 299 273.00)
DPY++ (e.g., DPY29)	300 to 399 329.00)
Two USOCs (e.g., CDR63 DPY00)	400 or greater 563.00)

g. Flat Installation Charge

Applies for the installation of noncomplex wire.

- Per order, per premises

- First Jack	HRDJ1	\$ 60.00
- Each Additional	HRDS1	35.00

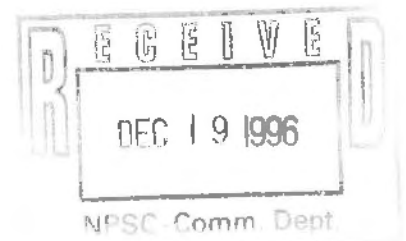

NOTICE

THE INFORMATION CONTAINED IN THIS DOCUMENT IS SUBJECT TO CHANGE.

ARAPAHOE TELEPHONE COMPANY

Exchange and Network
Services Catalog

SECTION 13

Page 12

Release 1

State of Nebraska

Notified: 12-19-96

Effective: 1-2-97

13. CUSTOMER PREMISES WIRE AND MAINTENANCE PLANS

2. Premises Work Charges - Business

	USOC	NONRECURRING CHARGE
a. Premises Visit Charge	NRAC	\$ 20.00
b. Time and Material Charges (Installation)		
• Schedule I (Regular Scheduled Hours)		
Applicable to premises work performed during regularly scheduled business hours.		
- First 30 minute increment or fraction thereof	HRD11	41.00
- Each additional 15 minute increment or fraction thereof	HRDA1	16.00
• Schedule II (After Hours)		
Applicable to premises work performed at hours other than on Schedule I, excluding Sundays and holidays.		
- First 30 minute increment or fraction thereof	HRD12	55.00
- Each additional 15 minute increment or fraction thereof	HRDA2	23.00
• Schedule III (Premium Hours)		
Applicable to premises work performed on Sundays and holidays.		
- First 30 minute increment or fraction thereof	HRD13	65.00
- Each additional 15 minute increment or fraction thereof	HRDA3	26.00

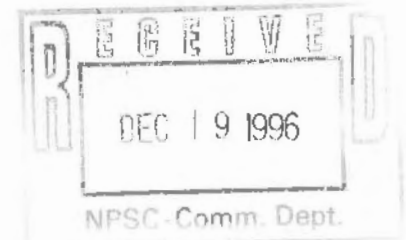

ARAPAHOE TELEPHONE COMPANY

Exchange and Network
Services Catalog

SECTION 13

Page 13

Release 1

State of Nebraska

Notified: 12-19-96

Effective: 1-2-97

13. CUSTOMER PREMISES WIRE AND MAINTENANCE PLANS

c. Time and Material Charges (Repair)

• Schedule I (Regular Scheduled Work Hours)

Applicable to premises work performed during regularly scheduled business hours.

- First 30 minute increment or fraction thereof	HRD11	41.00
- Each additional 15 minute increment or fraction thereof	HRDA1	16.00

• Schedule II (After Hours)

Applicable to premises work performed at hours other than on Schedule I, excluding Sundays and holidays.

- First 30 minute increment or fraction thereof	HRD12	55.00
- Each additional 15 minute increment or fraction thereof	HRDA2	23.00

• Schedule III (Premium Hours)

Applicable to premises work performed on Sundays and holidays.

- First 30 minute increment or fraction thereof	HRD13	65.00
- Each additional 15 minute increment or fraction thereof	HRDA3	26.00

d. Holidays

Holidays subject to Schedule III charges are:

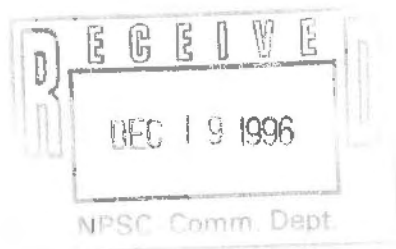

HOLIDAY	DAY OBSERVED
New Year's Day	January 1
Memorial Day	Last Monday in May
Independence Day	July 4
Labor Day	First Monday in September
Thanksgiving Day	Fourth Thursday in November
Christmas Day	December 25

NOTICE

THE INFORMATION CONTAINED IN THIS DOCUMENT IS SUBJECT TO CHANGE.

ARAPAHOE TELEPHONE COMPANY

Exchange and Network
Services Catalog

SECTION 13

Page 14

Release 1

State of Nebraska

Notified: 12-19-96

Effective: 1-2-97

13. CUSTOMER PREMISES WIRE AND MAINTENANCE PLANS

e. Material Used Not Billed

Normal installation and repair material: Staples, screws, nails, tape, connectors, etc.

f. Material Used/Billed

USOC	NONRECURRING CHARGE
AKT++ (e.g., AKT57)	\$ 1 to 99 57.00)
BAC++ (e.g., BACO1)	100 to 199 101.00)
CDR++ (e.g., CDR73)	200 to 299 273.00)
DPY++ (e.g., DPY29)	300 to 399 329.00)
Two USOCs (e.g., CDR63 DPY00)	400 or greater 563.00)

g. Flat Installation Charge

Applies for the installation of noncomplex wire.

- Per order, per premises

- First Jack	HRDJ1	\$ 90.00
- Each additional	HRDS1	45.00

3. Trouble Isolation Charge, per repair visit:

- Noncomplex	LTESX	25.00
- Complex	LTECX	37.00

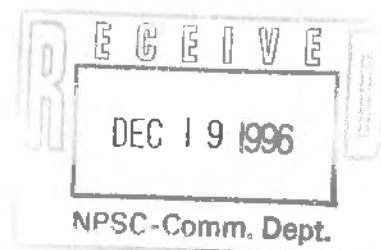

NOTICE

THE INFORMATION CONTAINED IN THIS DOCUMENT IS SUBJECT TO CHANGE.

ARAPAHOE TELEPHONE COMPANY

Exchange and Network
Services Catalog

SECTION 13

Page 15

Release 1

State of Nebraska

Notified: 12-19-96

Effective: 1-2-97

13. CUSTOMER PREMISES WIRE AND MAINTENANCE PLANS

13.2 PREMISES WIRE MAINTENANCE

A. Description

1. Premises Wire Maintenance Plans are available which provide customers with various degrees of Wire Maintenance as described below. These premises wire plans provide for trouble isolation and maintenance of noncomplex premises wire and associated jacks located on the customer side of the demarcation point.

2. The following plans are available:

- a. Residential Wire Maintenance Service

Residential Wire Maintenance Service is a monthly charge for residence customers paid in lieu of time and material charges for repairs associated with premises wire. This plan provides line testing, trouble isolation, and the repair of premises wire and connected jacks.

- b. Business Wire Maintenance Service

Business Wire Maintenance Service is a monthly charge for business customers paid in lieu of time and material charges for repairs associated with premises wire. This plan provides line testing, trouble isolation, and the repair of premises wire and connected jacks.

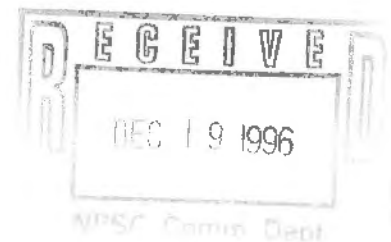

NOTICE

THE INFORMATION CONTAINED IN THIS DOCUMENT IS SUBJECT TO CHANGE.

ARAPAHOE TELEPHONE COMPANY

Exchange and Network
Services Catalog

SECTION 13

Page 16

Release 1

Effective: 1-2-97

State of Nebraska

Notified: 12-19-96

13. CUSTOMER PREMISES WIRE AND MAINTENANCE PLANS

B. Terms and Conditions

1. The Company will maintain premises wire regardless of who installed it, providing the wire meets technical standards.
2. When a trouble condition is attributed in the presence of non standard wiring or installation, only that portion of the wiring and jacks, where the problem exists, will be rewired, if necessary, using standard wire, jacks and installation methods. The Company will not entirely rewire the premises even though non standard wire may have been used on other working jacks. Rewiring work that is required to remedy an existing case of trouble will be performed in a reasonable manner.
3. If a customer does not subscribe to a Premises Wire Maintenance Plan and the Company makes either a repair or trouble isolation visit to that customer's premises and the trouble condition is not found to be on Company's side of the demarcation point, the customer will be subject to charges as follows:
 - a. A Trouble Isolation Charge will apply for the visit if the customer does not have the Company repair the premises wire trouble.
 - b. A Trouble Isolation Charge will apply for the visit when the technician is able to gain access to the demarcation point whether or not the customer is at the premises.
 - c. A Trouble Isolation Charge and Premises Work Charges will apply if the Company repairs the premises wire trouble or isolates the trouble to the customer-provided equipment.
 - d. A Premises Visit Charge and Premises Work Charges will apply if the customer has isolated the trouble and has the Company make the appropriate repairs.
4. Premises Wire Maintenance Plans are available where Company facilities and operating conditions permit.
5. Premises Wire Maintenance Plans are subject to a minimum billing period of one month.
6. A customer utilizing noncomplex premises wire may change from paying T&M per maintenance visit or from customer-provided maintenance to a Premises Wire Maintenance Plan as appropriate. However, a nonrecurring charge will be assessed for this change. Existing service problems are excluded from coverage when a customer changes from T&M to a maintenance plan.

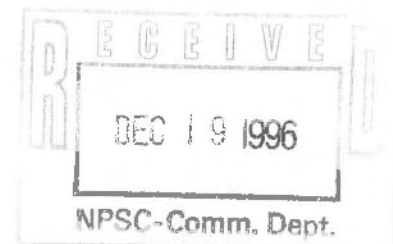

NOTICE

THE INFORMATION CONTAINED IN THIS DOCUMENT IS SUBJECT TO CHANGE.

ARAPAHOE TELEPHONE COMPANY

Exchange and Network
Services Catalog

SECTION 16

Index Page 1

Release 1

Effective: 1-2-97

State of Nebraska

Notified: 12-19-96

16. PROMOTIONS

SUBJECT

PAGE

Special Promotions..... 1

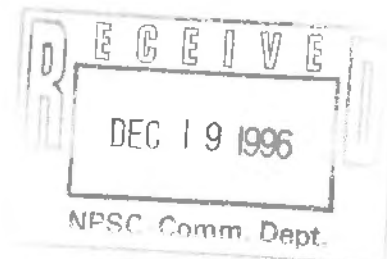

NOTICE

THE INFORMATION CONTAINED IN THIS DOCUMENT IS SUBJECT TO CHANGE.

ARAPAHOE TELEPHONE COMPANY

Exchange and Network
Services Catalog

SECTION 16

Page 1

Release 1

State of Nebraska
Notified: 12-19-96

Effective: 1-2-97

16. PROMOTIONS

16.1 SPECIAL PROMOTIONS

CONVERSION PROMOTION

A special promotion is available and applicable only for residence customers whose telephone service is served from central offices that have been converted to electronic technology since February 1, 1993. During certain promotional periods, applicable residence customers who have orders placed and/or completed for Call Forwarding, Call Waiting, Three-Way Calling and/or Speed Calling 8 and/or 30 code whether purchased separately or in a Custom Calling Services package, will be offered a special 60 day money back guarantee and waiver of nonrecurring charges as follows:

- The nonrecurring charges for the service(s) ordered will be waived.
- A 60 day money back guarantee on the monthly rate is available to residence customers who subscribe to the features listed above either separately or in a package.
- Customers requesting the 60 day money back guarantee must do so and request the Company to disconnect the particular service(s) no later than 60 days after the installation date.
- Customers requesting the 60 day money back guarantee will be given credit from the time of installation of the service to the disconnect date, not to exceed 60 days.



NOTICE

THE INFORMATION CONTAINED IN THIS DOCUMENT IS SUBJECT TO CHANGE.